Table of Contents

MS45

Subject	Page
MS452
Objectives of the Module2
Purpose of the System3
System Components4
Power Supply6
Principle of Operation7
Workshop Hints8
Tools and Equipment9
Air Management10
Principle of Operation18
Workshop Hints22
Tools and Equipment25
Fuel Management26
Principle of Operation32
Workshop Hints38
Tools and Equipment42
Ignition Management43
Principle of Operation48
Workshop Hints52
Tools and Equipment58
Emissions Management60
Evaporative Emissions60
Exhaust Emissions64
Principle of Operation70
Workshop Hints81
Tools and Equipment83
Performance Controls84
Tools and Equipment91
Review Questions92

MS45

**Models: E85 Z4
E83 X3 - all except M54B30 automatic**

**Production Date: Start of Production MY 2003 - E85
Start of Production MY 2004 - E83**

Manufacturer: Siemens

Pin Connector: 134 Pins - 5 Modular Connectors

Objectives of the Module

After completing this module, you will be able to:

- Describe the Power Supply for the Fuel Injectors and Ignition Coils.
- Understand the EDK and Idle Air Actuator Operation.
- Name the Differences of the MS45 Fuel Supply System.
- List the Inputs Required for Fuel Injector Operation.
- Describe Emission Optimized Function.
- Name the Two Types of Emissions the ECM Controls.
- Explain Why Two Sensors are Used to Monitor Accelerator Pedal Movement.
- Understand DM TL Evaporative Leak Testing.
- Describe How the Ignition System is Monitored.

MS45

Purpose of the System

The MS45 system is an evolution of the MS43 system and manages the following functions:

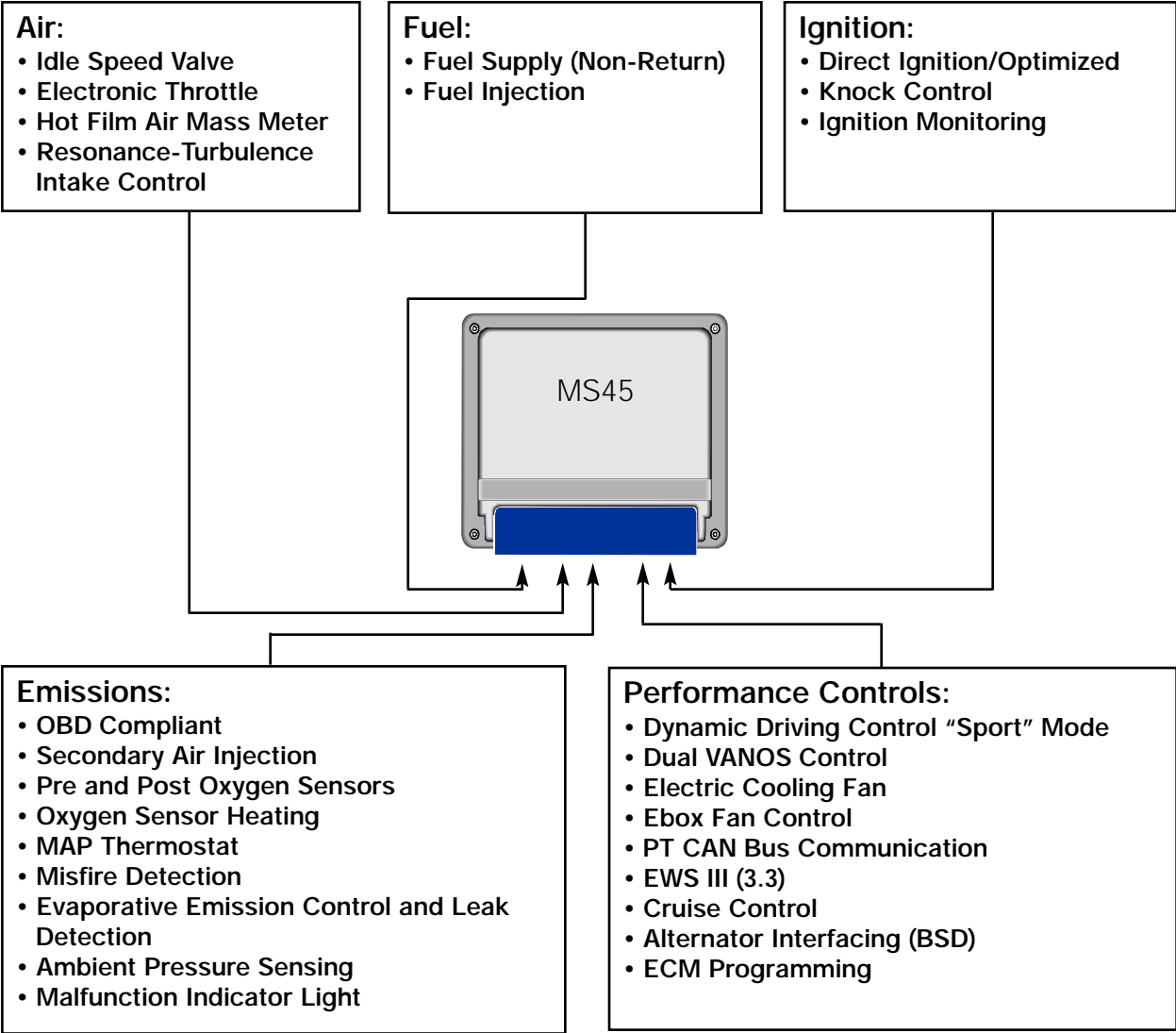

System Components

MS45 Engine Control Module: The Engine Control Module (ECM) features a single printed circuit board with two 32-bit microprocessors.

The task of the first processor is to control:

- Engine Load
- Electronic Throttle
- Idle Actuator
- Ignition
- Knock Control

The task of the second processor is to control:

- Air / Fuel Mixture
- Emission Control
- Misfire Detection
- Evaporative Leak Detection



12550000.tiff

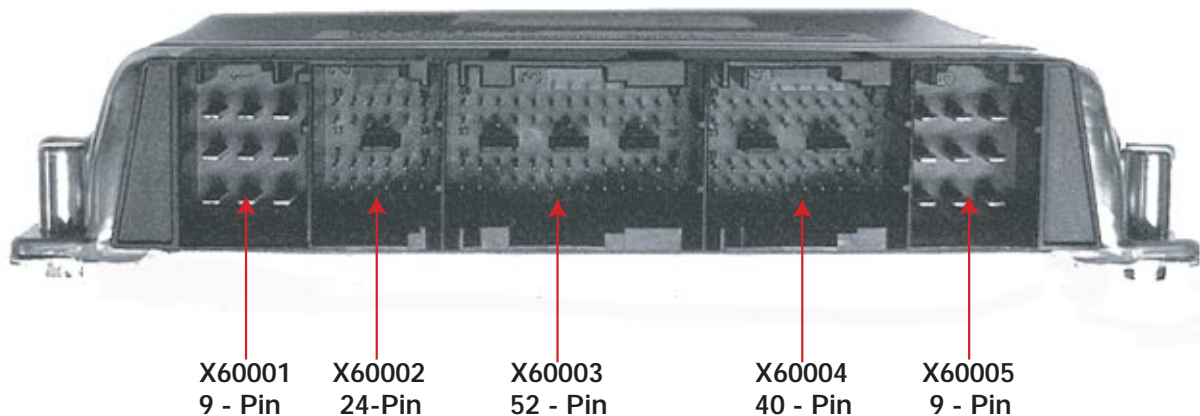

The 134 pin ECM is manufactured by Siemens to BMW specifications. The ECM is the SKE (standard shell construction) housing and uses 5 modular connectors. *For testing, use the Universal Adapter Set (break-out box) Special Tool # 90 88 6 121 300.*

System Components: Inputs - Processing - Outputs

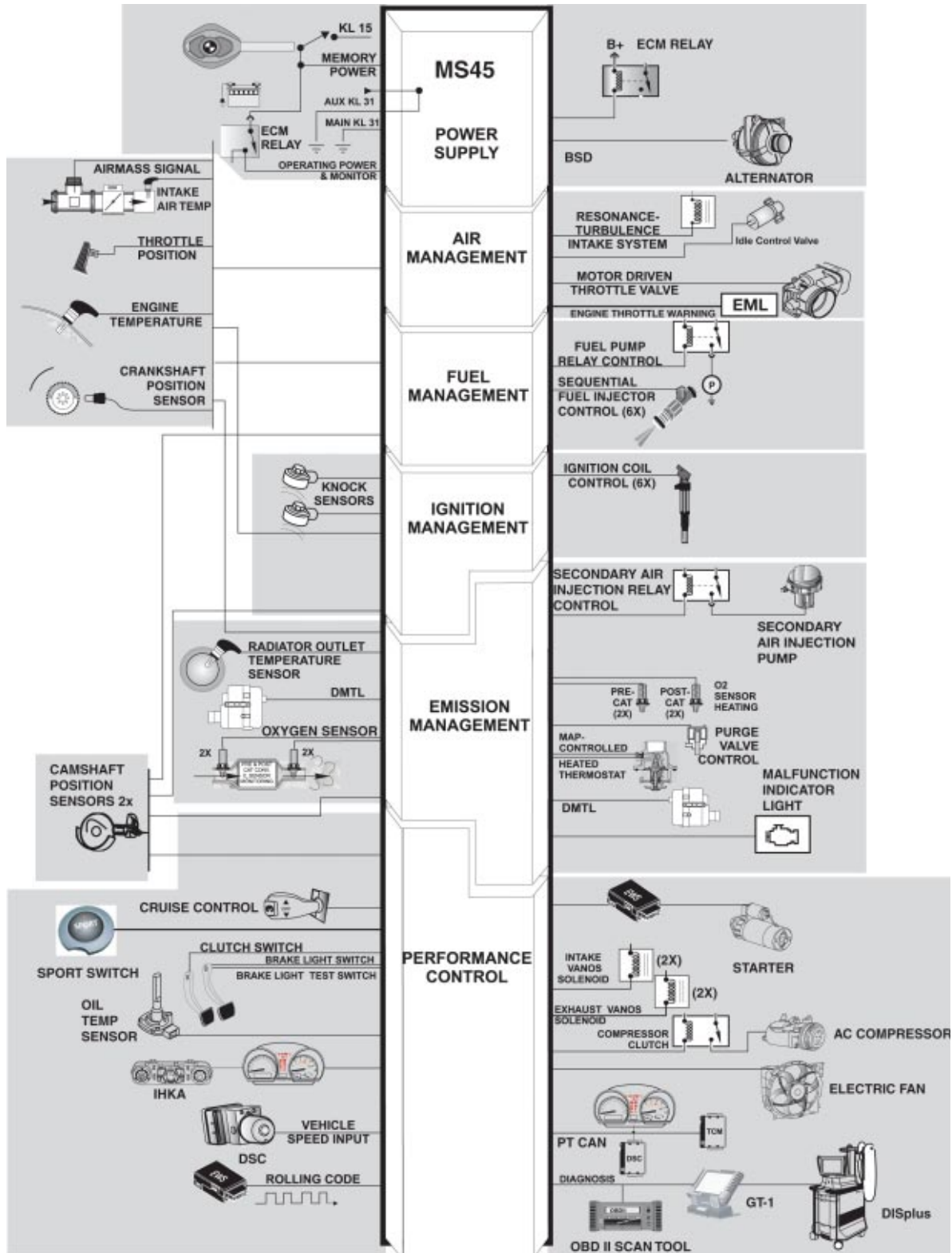

45-02-01

Power Supply

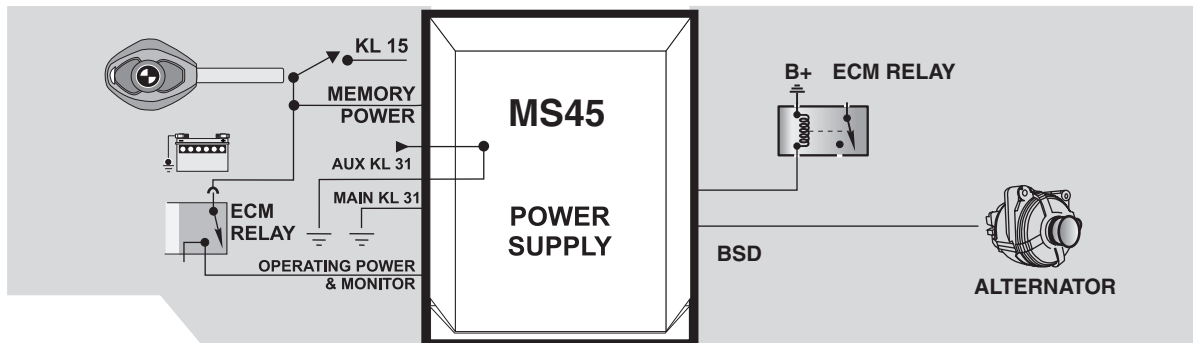

45-02-02

KL30 - Battery Voltage: B+ is the main supply of operating voltage to the ECM.

Power Supplies: The power supplies (KL15 and ECM Relay) are fused to the MS45 ECM. The fuses are housed in the Engine Fuse Block located in the Electronics Box.

KL15 - Ignition Switch: When the ignition is switched “on” the ECM is informed that the engine is about to be started. KL15 (fused) supplies voltage to the Engine Control Module Relay and the Fuel Injector Relay. Switching KL15 “off” removes the ECM operating voltage.

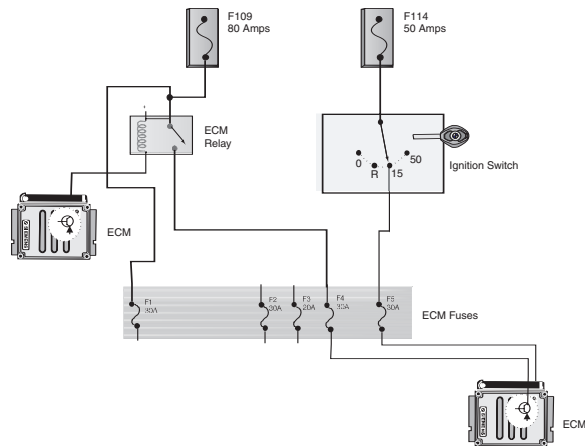

55-01-01

Engine Control Module Relay: The ECM Relay provides the operating voltage for:

1. ECM	6. Ignition Coil
2. Fuel Injection	7. Evaporative Leak Detection Pump
3. Idle Air Actuator	8. Camshaft Sensor
4. Evaporative Emission Valve	9. Hot Film Air Mass
5. Fuel Pump Relay	10. Oxygen Sensor Heaters

Ground: Multiple ground paths are necessary to complete current flow through the ECM.

Connector X60001	Connector X60005
Pin 4 – Ground for ECM	Pin 5 – Ground for ECM
Pin 5 – Ground for ECM	
Pin 6 – Ground for ECM	

Principle of Operation

Battery Voltage is monitored by the ECM for fluctuations. It will adjust the output functions to compensate for a lower (6v) and higher (14v) voltage value. For example, the ECM will:

- *Modify pulse width duration of fuel injection*
- *Modify dwell time of ignition*

When **KL15** is switched “on” the ECM is ready for engine management. The ECM will activate ground to energize the Engine Control Module Relay. The Engine Control Module Relay supplies operating voltage to the ECM and the previously mentioned operating components. Five seconds after the ignition is switched on and the voltage at the KL15 input is >9 volts, the ECM compares the voltage to the ECM Relay supplied voltage. If the voltage difference between the two terminals is greater than 3 volts, a fault code will be set.

When **KL15** is switched “off” the ECM operating voltage is removed. The ECM will maintain a ground to the Engine Control Module Relay for a few seconds to maintain ignition coil activation (Emission Optimized) and as long as *three minutes to complete the DM TL test*.

Ground is required to complete the current path through the ECM. The ECM also:

- Internal links a constant ground (1) to activate components
- Switches ground (2) to activate components

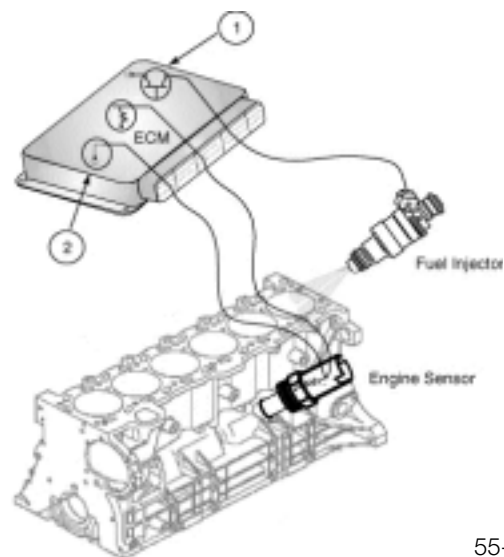

55-01-04

Workshop Hints

Power Supply - Testing

1. ECM (DME)
2. EGS or SMG (if equipped)
3. ECM main relay
4. Fuel injector relay
5. - SMG (if equipped) hydraulic pump relay
- EGS (if equipped) reverse light relay

Inadequate power and ground supply can result in:

1. No Start
2. Hard Starting (Long Crank Times)
3. Inaccurate Diagnosis Status or ECM (not found)
4. Intermittent/Constant "Engine Emission/EML" Light
5. Intermittent/Constant Driveability Problems

Power supply including *fuses* should be tested.

The ignition (KL15) must be switched off when removing or installing the ECM connector to prevent voltage spikes (arcing) that can damage the Control Module!

The Engine Control Module *Relay* (located in the Electronics Box) should be tested for:

1. Battery Voltage and Switched Ground (1)
2. Resistance (1)
3. Battery Voltage and Voltage Drop (2)

E85 Electronics Box - ECM and Fuses

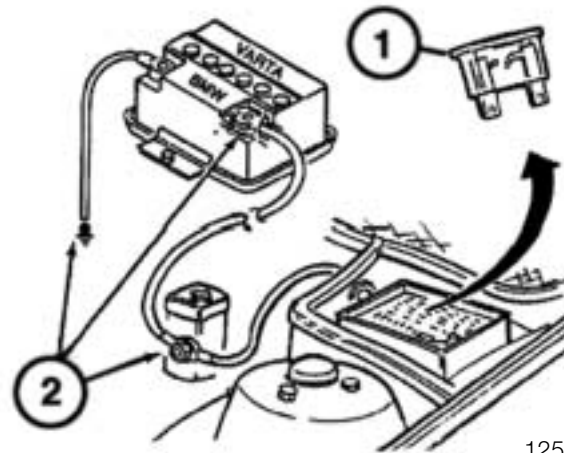

12550001

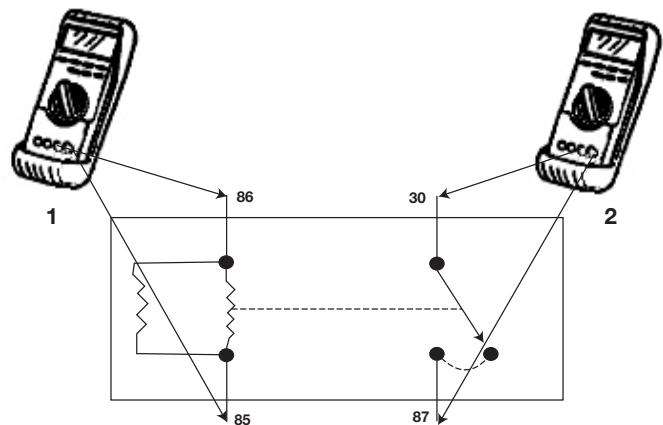

12410004

Tools and Equipment

Power Supply

When testing power supply to an ECM, the DISplus/GT1 multimeter function as well as a reputable hand held multimeter can be used.

It is best to make the checks at the ECM connection, this method includes testing the wiring harness.

The correct Universal Adapter for the MS45 application should be used (#90 88 6 121 300). This will ensure the pin connectors and the harness will not be damaged.

When installing the Universal Adapter to the ECM (located in the Electronics Box in the engine compartment), make sure the ignition is switched off.

NOTE for MS45: Allow at least 3 minutes to elapse after the key was set to the "OFF" position before disconnecting the ECM/ TCM.

This will allow sufficient time to complete the DM TL test. Voltage may be present (up to 3 minutes) causing damage to the ECM/TCM if they are disconnected during this time period (arcing).

The Engine Control Module **Relay** should be tested using the relay test kit (P/N 88 88 6 613 010) shown on the right.

This kit allows testing of relays from a remote position. Always consult the ETM for proper relay connections.

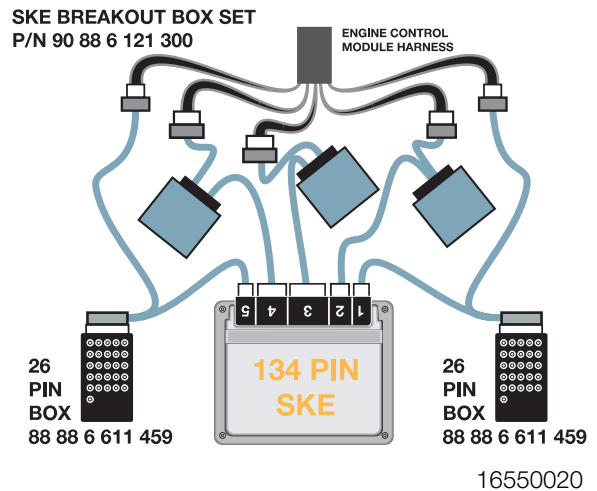

12550003

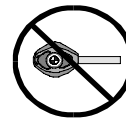

12550001

Air Management

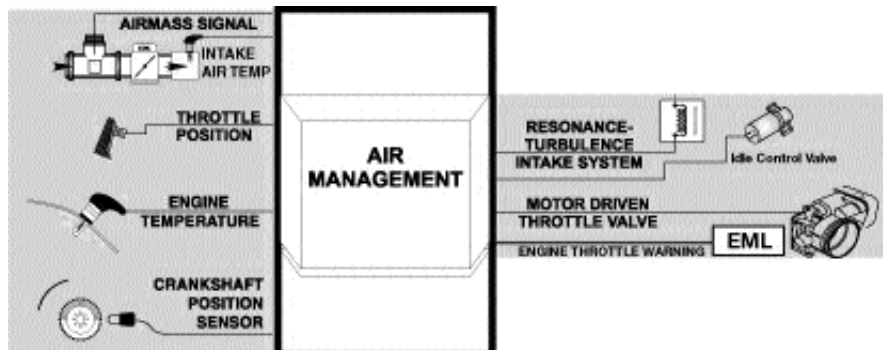

45-02-03

Throttle Valve: The throttle valve plate is electronically operated to regulate intake air flow by the ECM. The purpose is for precision throttle operation, OBD compliant for fault monitoring, DSC and Cruise Control. This integrated electronic throttle reduces extra control modules, wiring, and sensors. *Adjusting electronic throttles is not permitted, the throttle assembly must be replaced as a unit. The adaptation values must be cleared and adaptation procedure must be performed using the DISplus/GT1.*

The throttle assembly for the MS45 system is referred to as the EDK. The EDK is distinguished by:

- EDK does not contain a PWG, It is remotely mounted (integrated in the accelerator pedal assembly).
- The accelerator pedal is not mechanically “linked” to the EDK.

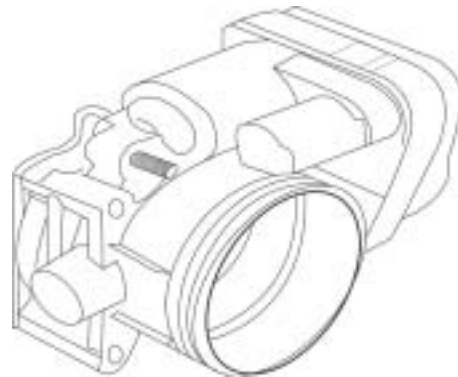

16550007

Throttle Position Sensor: The accelerator pedal module provides two variable voltage signals to the ECM that represents accelerator pedal position and rate of movement.

Dual Hall Sensors are integral in the accelerator pedal module. The ECM compares the two values for plausibility. The module contains internal springs to return the accelerator pedal to the rest position.

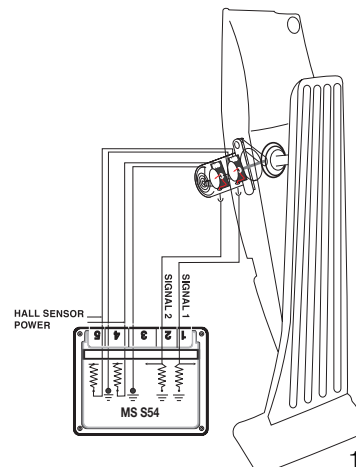

13550011.eps

The ECM provides voltage (5v) and ground for the Hall sensors. As the accelerator pedal is moved from rest to full throttle, the sensors produce a variable voltage signal.

- Hall sensor 1(request) = 0.5 to 4.5 volts
- Hall sensor 2 (plausibility) = 0.5 to 2.0 volts

If the signals are not plausible, the ECM will use the lower of the two signals as the requested input. The throttle response will be slower and the maximum throttle response will be reduced.

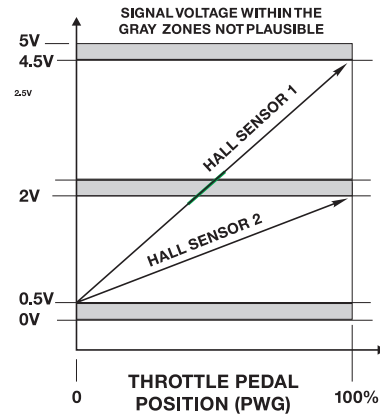

13550012

Throttle Motor and Feedback Position: The MS45 ECM powers the EDK motor using pulse width modulation for opening and closing the throttle plate. The throttle plate is also closed by an integrated return spring.

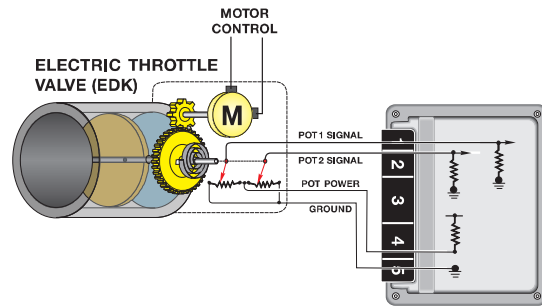

13550002

Two integrated potentiometers provide voltage feedback signals to the ECM as the throttle plate is opened and closed.

- Feedback signal 1 provides a signal from 0.5v (closed) to 4.5 V (Full Throttle)
- Feedback signal 2 provides a signal from 4.5v (closed) to 0.5V (Full Throttle)

Potentiometer 1 is the primary feedback signal of throttle plate position and signal 2 is the plausibility cross check through the complete throttle plate movement.

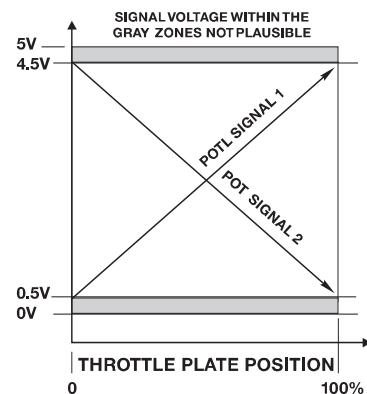

13550005

Idle Air Actuator: This valve regulates air by-passing the throttle valve to control the engine idle/low speed.

The valve is supplied with battery voltage from the ECM Relay. The Idle Air Actuator is a two-coil rotary actuator. The ECM is equipped with two final stage transistors which will alternate positioning of the actuator.

The final stages are "pulsed" simultaneously by the ECM which provides ground paths for the actuator. The duty cycle of each circuit is varied to achieve the required idle RPM.

If this component/circuits are defective, a fault code will be set and the "Malfunction Indicator Light" will be illuminated when the OBD II criteria is achieved.

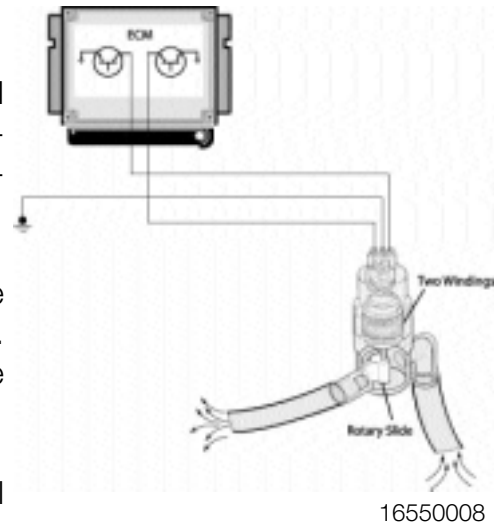

Hot-Film Air Mass Meter (HFM): The air volume input signal is produced electronically by the HFM which uses a heated metal film (180° C above intake air temperature) in the air flow stream.

The ECM Relay provides the operating voltage. As air flows through the HFM, the film is cooled changing the resistance which affects current flow through the circuit. The sensor produces a 1-5 volt varying signal. Based on this change the ECM monitors and regulates the amount of injected fuel.

If this input is defective, a fault code will be set and the "Malfunction Indicator Light" will be illuminated when the OBD II criteria is achieved. The ECM will operate the engine using the Throttle Position and Engine RPM inputs.

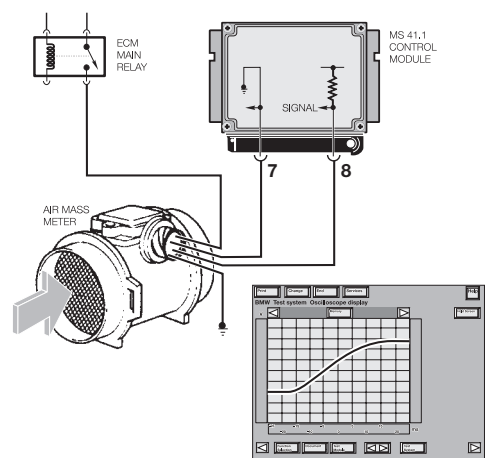

13550017

NOTE: *The HFM is non-adjustable.*



13550004

Air Temperature Signal: The HFM contains an integral air temperature sensor. This is a Negative Temperature Coefficient (NTC) type sensor. This signal is required by the ECM to correct the air volume input for changes in the intake air temperature (air density) affecting the amount of fuel injected, ignition timing and Secondary Air Injection activation.

The ECM provides the power supply to the sensor which decreases in resistance as the temperature rises and vice versa. The ECM monitors an applied voltage to the sensor that will vary as air temperature changes the resistance value.

If this input is defective, a fault code will be set and the “Malfunction Indicator Light” will be illuminated when the OBD II criteria is achieved. The ECM will operate the engine using the Engine Coolant Sensor input as a back up.



13550004

Notes:

Resonance/Turbulence Intake System: On the M54, the intake manifold is split into two groups of three (runners) which increases low end torque. The intake manifold also has separate (internal) turbulence bores which channels air from the idle speed actuator directly to one intake valve of each cylinder (matching bore of 5.5mm in the cylinder head).

Routing the intake air to only one intake valve causes the intake to swirl in the cylinder. Together with the high flow rate of the intake air due to the small intake cross sections, this results in a reduction in fluctuations and more stable combustion.

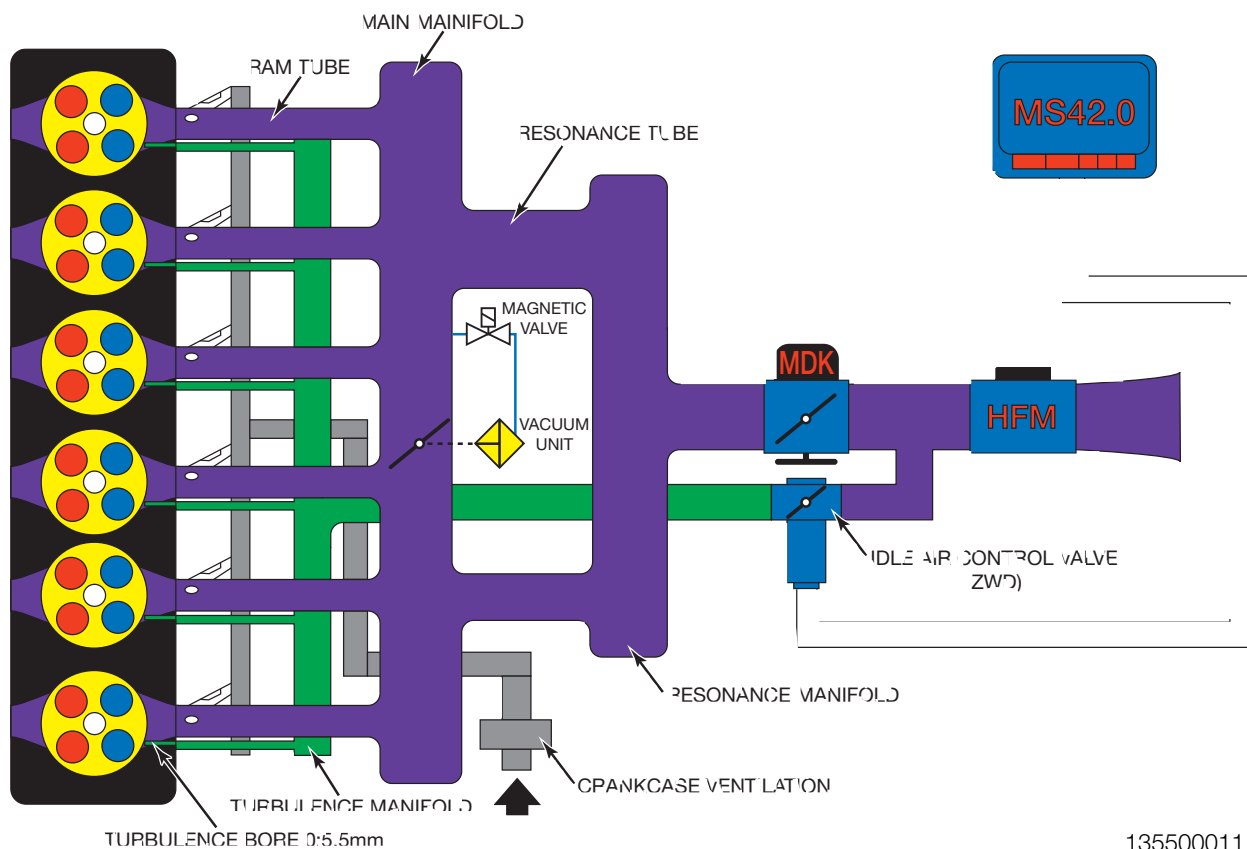

Resonance System: The resonance system provides increased engine torque at low RPM, as well as additional power at high RPM. Both of these features are obtained by using an ECM controlled resonance flap (in the intake manifold).

During the low to mid range rpm, the resonance flap is closed. This produces a long/single intake tube which increases engine torque.

During mid range to high rpm, the resonance flap is open. This allows the intake air to draw through both resonance tubes, providing the air volume necessary for additional power at the upper RPM range.

The Resonance Flap (shown on the right) is closed when vacuum is applied and sprung open. This is a unitized assembly that is bolted into the intake manifold.



135500012

The ECM controls a solenoid valve for resonance flap activation. At speeds below 3750 RPM, the solenoid valve is energized and vacuum supplied from an accumulator closes the resonance flap. This channels the intake air through one resonance tube, but increases the intake velocity.

When the engine speed is greater than 3750 RPM (which varies slightly - temperature influenced), the solenoid is de-energized. The resonance flap is sprung open, allowing flow through both resonance tubes, increasing volume.

When the flap is closed, this creates another “dynamic” effect.

- #1 Cylinder Intake Valve open low to Mid Range RPM (<3750 RPM).
- #1 Cylinder Intake Valve closes #5 Intake Valve Open => Intake Air Bounce Effect low to Mid Range RPM (<3750 RPM).

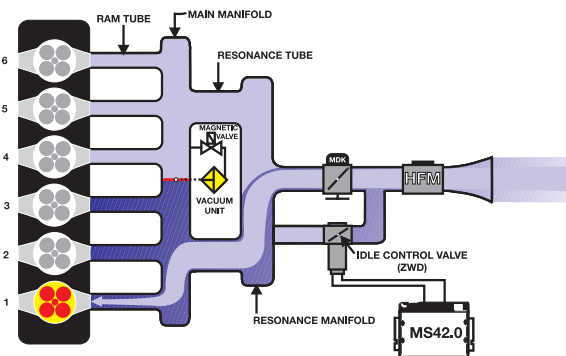

13550010

As the intake air is flowing into cylinder #1, the intake valves will close.

This creates a “block” for the in rushing air. The air flow will stop and expand back (resonance wave back pulse) with the in rushing air to cylinder #5.

- #1 Cylinder Intake Valve closes #5 Intake Valve Open => Intake Air Bounce Effect Low to Mid Range RPM (<3750 RPM)).

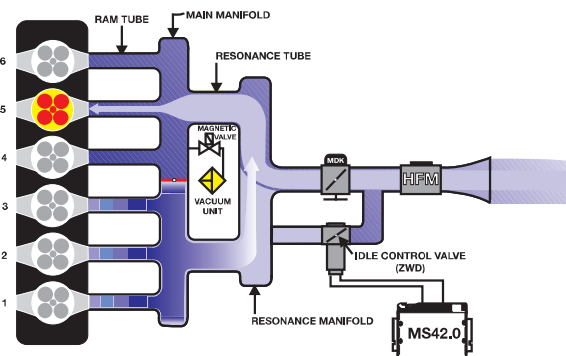

13550009

The resonance “wave”, along with the intake velocity, enhances cylinder filling.

When the engine speed is greater than 3750 RPM the solenoid is de-energized. The resonance flap is sprung open, allowing flow through both resonance tubes, increasing volume.

- #1 Cylinder Intake Valve Open - Intake air drawn from both resonance tubes. Mid to High Range (>3750 RPM)

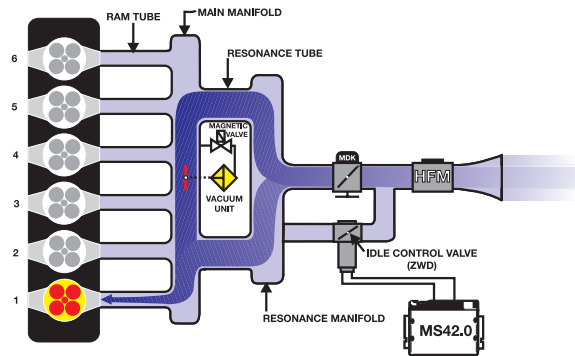

13550008

- #5 Cylinder Intake Valve Open - Intake air drawn from both resonance tubes. Mid to High Range RPM (>3750 RPM).

The resonance “wave”, along with the intake volume, enhances cylinder filling.

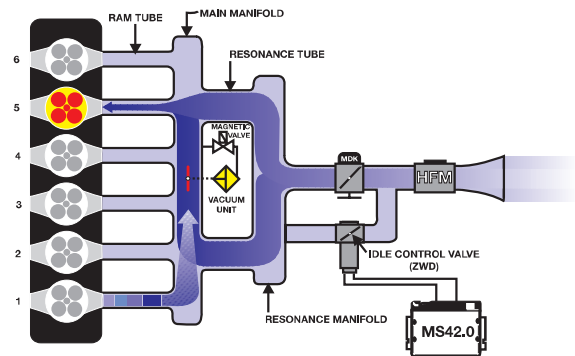

1355000007

Pressure Control Valve: The pressure control valve varies the vacuum applied to the crankcase ventilation depending on engine load. The valve is balanced between spring pressure and the amount of manifold vacuum.

The oil vapors exit the separator labyrinth (2) in the cylinder head cover (1). The oil vapors are drawn into the cyclone type liquid/vapor separator (3) regulated by the pressure control valve (5).

The oil vapors exit the pressure control valve into the intake manifold. The collected oil will drain back into the oil pan (4).

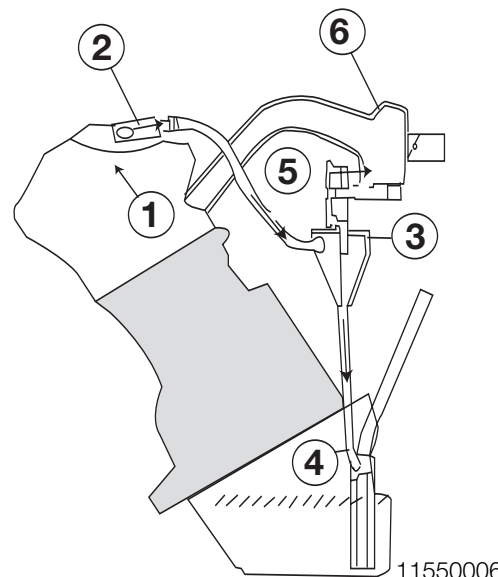

11550006

The vapors exit the pressure control valve and are drawn into the intake manifold through an external distribution tube (2). The tube has a splice at the front to equally distribute vapors to the back.

As the vapors exit the pressure control valve, they are drawn into the intake manifold through this external tube for even distribution.

At idle when the intake manifold vacuum is high, the vacuum reduces the valve opening allowing a small amount of crankcase vapors to be drawn into the intake manifold.

At part to full load conditions when intake manifold vacuum is lower, the spring opens the valve and additional crankcase vapors are drawn into the intake manifold.

- 1. Engine Oil Vapors
- 2. Collective Drain Back Oil
- 3. Oil Vapors to the Intake Manifold

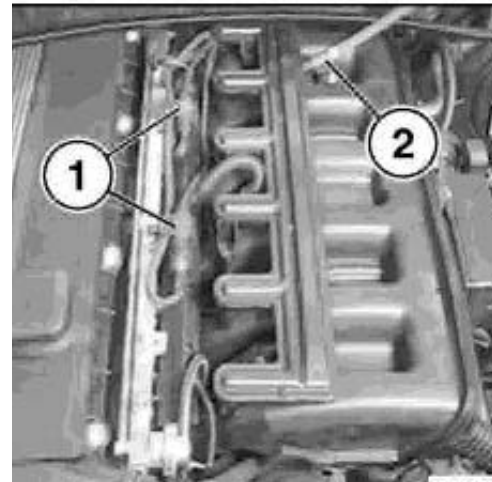

135500021

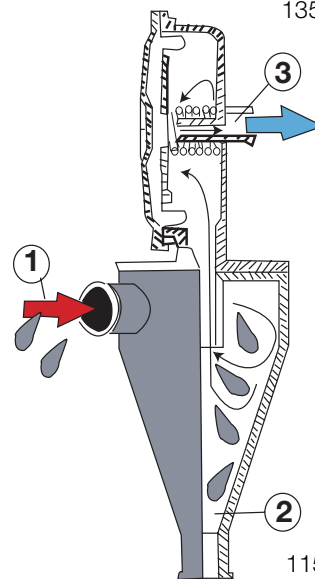

11550007

Notes:

Principle of Operation

Air flow into the engine is regulated by the Throttle Valve and/or the Idle Air Actuator. Both of these air “passages” are necessary for smooth engine operation from idle to full load. On the MS45 system, the Throttle Valve and the Idle Air Actuator are **electrically controlled**. All of the ECM monitoring, processing and output functions are a result of regulated air flow.

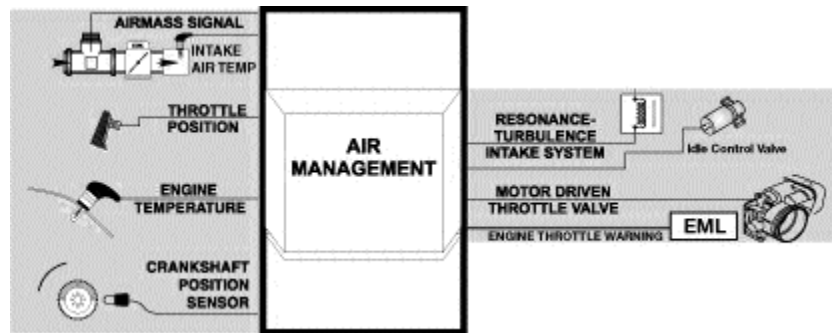

45-02-02

The Accelerator Pedal Position (PWG) is monitored by the ECM for pedal angle position and rate of movement. As the accelerator is moved, a rising voltage signal from the potentiometers/Hall sensors requests acceleration and at what rate. The ECM will increase the volume of fuel injected into the engine, advance the ignition timing and open the Throttle Valve and/or Idle Air Actuator.

The “full throttle” position indicates maximum acceleration to the ECM, and in addition to the functions just mentioned, this will have an effect on the air conditioning compressor (covered in Performance Controls).

As the accelerator pedal is released (integral springs), a decrease in voltage signals the ECM to activate fuel shut off if the RPM is above idle speed (coasting). The Throttle Valve will be closed and Idle Air Actuator Valve will open to maintain idle speed.

The ECM monitors the engine idle speed in addition to the accelerator pedal position and throttle position voltage. If the voltage values have changed (mechanical wear of throttle plate or linkage), the ECM will adjust the Idle Air Actuator to maintain the correct idle speed.

The potentiometers/Hall sensors are non-adjustable because the ECM “learns” the throttle angle voltage at idle speed. If the throttle housing/accelerator pedal module is replaced, the ***adaptations must be cleared and adaptation procedure must be performed using the DISplus/MoDIC. If this is not performed, the vehicle will not start, or run in “fail-safe” mode.***

If this input is defective, a fault code will be stored and the “Malfunction Indicator and/or EML” Light will be illuminated. Limited engine operation will be possible.

The MS45 PWG pedal position sensor consists of two separate Hall sensors with different voltage characteristics and independent power supply (located in the accelerator pedal module).

The pedal position sensor is monitored by checking each individual sensor circuit and comparing the two pedal values. Monitoring is active as soon as the sensors receive voltage (KL15). The ECM decides what operating mode the pedal position sensor is to assume.

- Mode = Pedal position sensor fully operable.
- Mode 1 = Failure of one pedal position sensor (maximum engine speed is limited).
- Mode 2 = Failure of both pedal position sensors (engine speed limited to 1500 rpm).

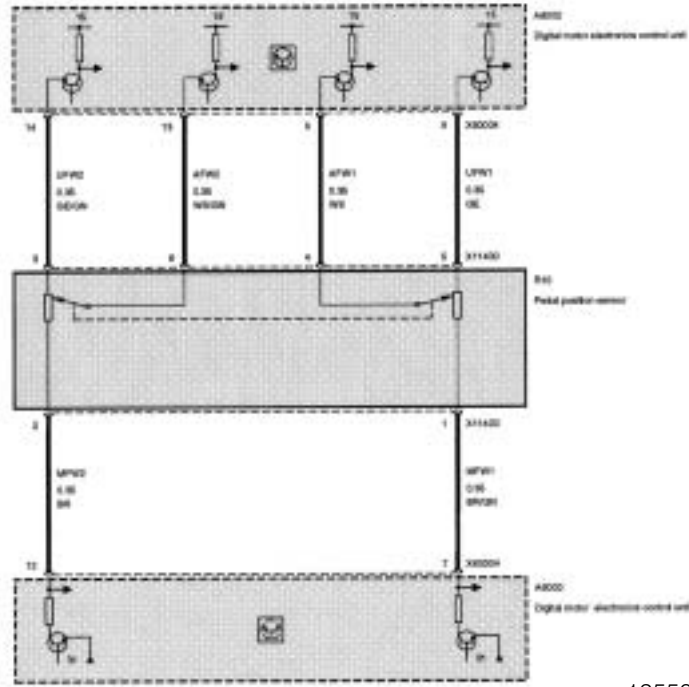

12550001

The Idle Air Actuator is controlled by the ECM modulating the ground signals (PWM at 100 Hz) to the valve. By varying the duty cycle applied to the windings, the valve can be progressively opened, or held steady to maintain the idle speed.

The ECM controls the Idle Air Actuator to supply the necessary air to maintain idle speed. When acceleration is requested and the engine load is low (<15%), the actuator will also supply the required air.

The basic functions of the idle speed control are:

- Control the initial air quantity (air temp <0° C, EDK is simultaneously opened).
- Variable preset idle based on load and inputs.
- Monitor RPM range intake for each preset position.
- Vacuum Limitation
- Smooth out the transition from acceleration to deceleration.

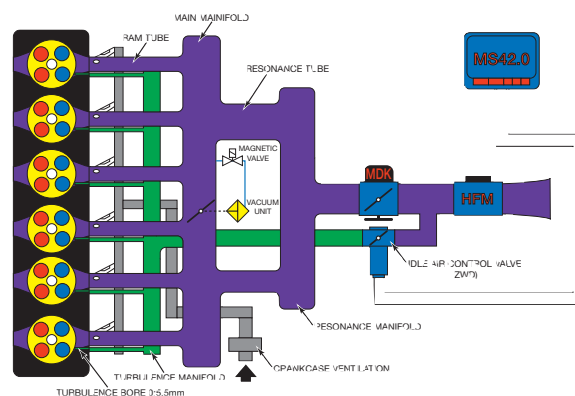

135500011

Under certain engine operating parameters, the EDK throttle control and the Idle Air Actuator are operated simultaneously. This includes all idling conditions and the transition from off idle. As the request for load increases, the idle valve will remain open and the EDK will supply any additional air volume required to meet the demand.

Backup Operation of Idle Air Actuator:

If a fault is detected with the Idle Air Actuator, the ECM will initiate failsafe measures depending on the effect of the fault (increased air flow or decreased air flow). If there is a fault in the Idle Air Actuator/circuit, the EDK will compensate to maintain idle speed. The “Malfunction Indicator and/or EML” Light will be illuminated to inform the driver of a fault.

If the fault causes increased air flow (actuator failed open), VANOS and Knock Control are deactivated which noticeably reduces engine performance.

The MS45 EDK Feedback Signal Monitoring/Backup Operation when a fault is detected in the system is as follows:

- The EDK provides two separate signals from two integrated potentiometers (Pot 1 and Pot 2) representing the exact position of the throttle plate.
- EDK Pot 1 provides the primary throttle plate position feedback. As a redundant safety feature, Pot 2 is continuously cross checked with Pot 1 for signal plausibility.
- If plausibility errors are detected between Pot 1 and Pot 2, MS45 will calculate the inducted engine air mass (from HFM signal) and only utilize the potentiometer signal that closely matches the detected intake air mass.
 - The MS 43.0 uses the air mass signaling as a “virtual potentiometer” (Pot 3) for a comparative source to provide failsafe operation.
 - If MS 43.0 cannot calculate a plausible conclusion from the monitored Pots (1 or 2 and virtual 3) the EDK motor is switched off and fuel injection cut out is activated (Failsafe operation if not possible).
- The EDK is continuously monitored during all phases of engine operation. It is also briefly activated/adapted when KL 15 is initially switched on as a “preflight check” to verify its mechanical integrity (no binding, appropriate return spring tension, etc). This is accomplished by monitoring both the motor control amperage and the reaction speed of the EDK feedback potentiometers. If faults are detected the EDK motor is switched off and the fuel injection cut off is activated (failsafe operation is not possible). The engine does however continue to run extremely rough at idle speed.
- When in emergency operation, the engine speed is always limited to 1300 RPM by fuel injector cutout, and activation of the “EML” light to alert the driver of a fault.
- When in emergency operation, the engine speed is always limited to 1300 RPM by fuel injector cutout, and activation of the “EML” light to alert the driver of a fault.
- When a replacement EDK is installed, the MS45 adapts to the new component (required amperage draw for motor control, feedback pot tolerance difference, etc). This occurs immediately after the next cycle of KL15 for approximately 30 seconds. During this period of adaptation, the maximum opening of the throttle plate is 25%.

The Total Intake Air Flow Control is performed by the ECM simultaneously operating the EDK throttle control and the Idle Air Actuator.

The ECM detects the driver's request from the potentiometers/Hall Sensors monitoring the accelerator pedal position. This value is added to the Idle Air control value and the total is what the ECM uses for EDK activation. The ECM then controls the Idle Air Actuator to satisfy the idle air "fill". In addition, the EDK will also be activated = pre-control idle air charge. Both of these functions are utilized to maintain idle RPM.

The EDK is electrically held at the idle speed position, and all of the intake air is drawn through the Idle Air Actuator. Without a load on the engine (<15%), the EDK will not open until the extreme upper RPM range. If the engine is under load (>15%), the Idle Air Actuator is open and the EDK will also open.

The Hot-Film Air Mass Meter (HFM) varies voltage monitored by the ECM representing the measured amount of intake air volume. This input is used by the ECM to determine the amount of fuel to be injected.

The heated surface of the hot-film in the intake air stream is regulated by the ECM to a constant temperature of 180° C above intake air temperature. The incoming air cools the film and the ECM monitors the changing resistance which affects current flow through the circuit. The hot-film does not require a "clean burn", it is self cleaning due to the high operating temperature for normal operation.

If this input is defective, a fault code will be set and the "Malfunction Indicator Light" will illuminate when the OBD II criteria is achieved. The ECM will maintain engine operation based on the Throttle Position Sensors and Crankshaft Position/Engine Speed Sensor.

The Air Temperature signal allows the ECM to make a calculation of intake air temperature. The varying voltage input from the NTC sensor indicates the larger proportion of oxygen found in cold air, as compared to less oxygen found in warmer air. The ECM will adjust the amount of injected fuel because the quality of combustion depends on oxygen sensing ratio.

The ignition timing is also affected by air temperature. If the intake air is hot the ECM retards the base ignition timing to reduce the risk of detonation. If the intake air is cooler, the base ignition timing will be advanced. The ECM uses this input as a determining factor for Secondary Air Injection activation (covered in the Emissions section).

If this input is defective, a fault code will be set and the "Malfunction Indicator Light" will illuminate when the OBD II criteria is achieved. The ECM will maintain engine operation based on the HFM and Engine Coolant Temperature sensor.

Workshop Hints

Air Management

Unmetered air leaks can be misleading when diagnosing faults causing “Malfunction Indicator Light”/driveability complaints.

Crankcase Ventilation System

A fault in this system can often “mislead” diagnosis. This type of fault can produce:

Please refer to the following Service Information Bulletins for details on the *Crankcase Ventilation System*:

- Mixture/misfire detected codes
- Whistling noise
- Performance/driveability complaints

Throttle Position Sensors - Testing

The Throttle Position Sensors can be tested with the following methods:

- DISplus Status Page (approx. 0.5v. to 4.5v)
- DISplus Oscilloscope - Select from the Present measurement which requires taking the measurement with the ECM and the Universal Adapter connected to the circuit as shown on the right).

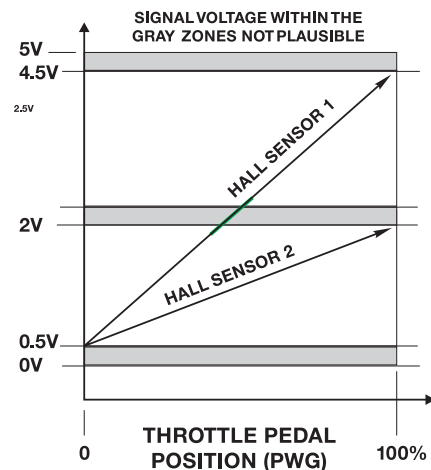

13410067

Idle Air Actuator Valve - Testing

- The Idle Air Actuator Valve and air circuit (passage ways) should be checked for physical obstructions. Visually inspect the sealing gasket, mounting bracket and air hose clamps.
- The resistance of the valve winding should be checked
- The ECM output and Idle Speed Control Valve operation can be tested by “Component Activation” on the DISplus/GT1.
- The Pulse Width Modulation ground outputs from the ECM can be tested using the DISplus/GT1 Oscilloscope.
- Consult Technical Data for specified idle speed.

NOTE: If the valve is blocked or contaminated, an HFM fault code can also be present.

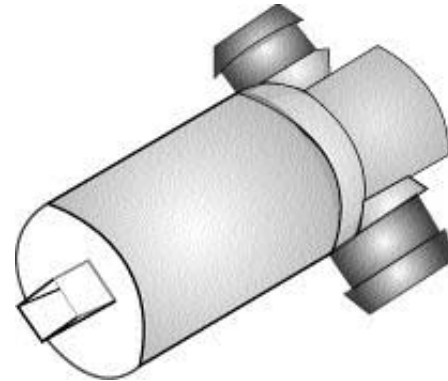

13550009

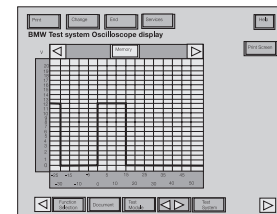
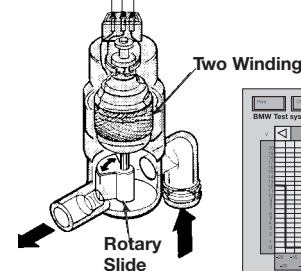
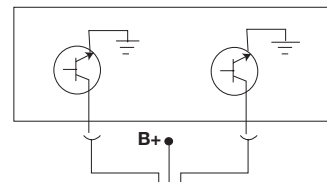

12550011

Air Temperature Signal - Testing

The HFM contains an integral air temperature sensor. NTC sensors decrease in resistance as the temperature rises and vice versa. The ECM monitors the sensor voltage which varies as temperature changes the resistance value. For example, as temperature rises:

- Resistance through the sensor decreases.
- Voltage drop across the sensor decreases.
- Input signal voltage also decreases (5-0v).

This sensor should be tested using:

- DISplus/GT1 Status Page
- DISplus/GT1 Multimeter (ohms)

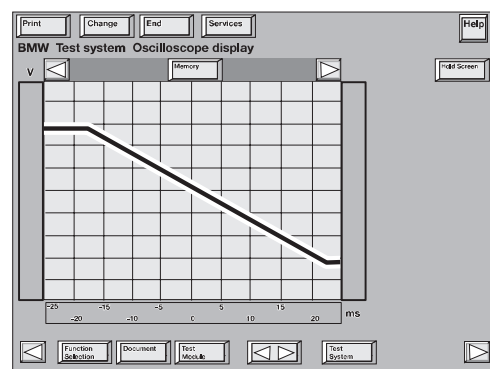

12550016

Hot-Film Air Mass Sensor

This component is non-adjustable and tampering is not permitted. A faulty Hot-Film Air Mass Sensor can produce the following complaints:

- Difficult To Restart When Engine Is Hot
- Engine Starts Then Stalls
- “Malfunction Indicator Light” Illuminated
- Engine Starts and Runs Only With Accelerator Pedal Depressed

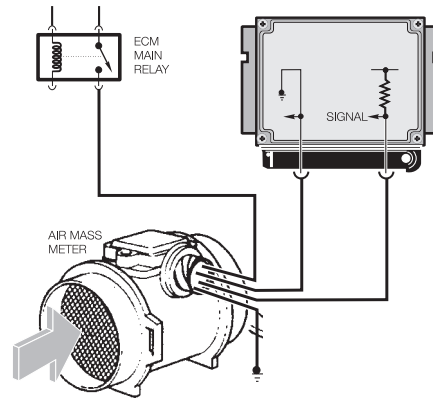

Testing: The Hot-Film Air Mass Sensor can be tested with the following methods:

- DISplus/GT1 Fault Code and Component Testing.
- DISplus/GT1 Status Page
- DISplus/GT1 Oscilloscope-which requires taking the measurement with the ECM and the Universal Adapter connected to the circuit (engine running).

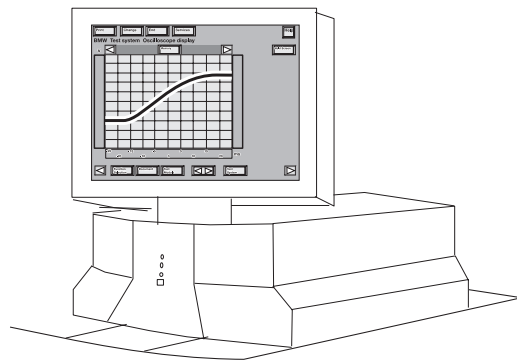

16550010

NOTE: Visually inspect the sensor for damaged, missing or blocked screens. The screens affect air flow calibration. Also inspect the sealing rings where the sensor inserts in the air filter housing and intake boot. Ensure the pin connections are tight.

Tools and Equipment

The DISplus/GT1 as well as a reputable hand held multimeter can be used when testing inputs/components.

It is best to make the checks at the ECM connection, this method includes testing the wiring harness.

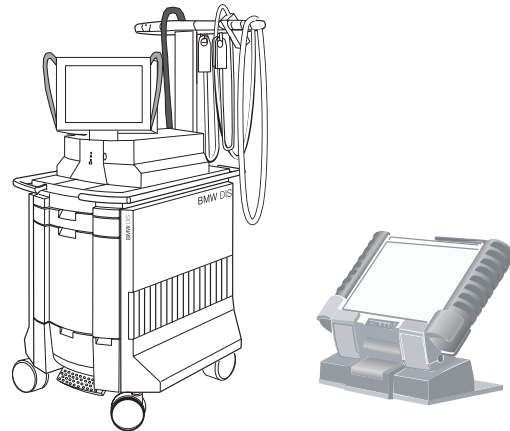

DISplus

GT-1 16550019

The correct Universal Adapter for the MS45 application should be used (#90 88 6 121 300). This will ensure the pin connectors and the harness will not be damaged.

When installing the Universal Adapter to the ECM (located in the Electronics Box in the engine compartment), make sure the ignition is switched off.

SKE BREAKOUT BOX SET
P/N 90 88 6 121 300

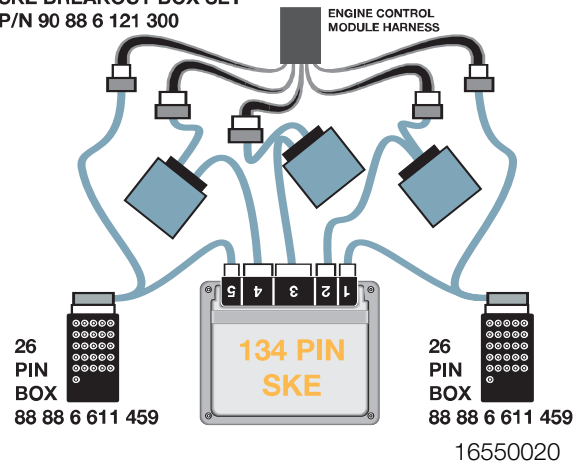

NOTE for MS45: Allow at least 3 minutes to elapse after the key was set to the "OFF" position before disconnecting the ECM/ TCM.

This will allow sufficient time to complete the DM TL test. Voltage may be present (up to 3 minutes) causing damage to the ECM/TCM if they are disconnected during this time period (arcing).

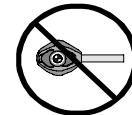

The Slack Tube Manometer Test Tool (#99 00 0 001 410) should be used to troubleshoot crankcase ventilation valves.

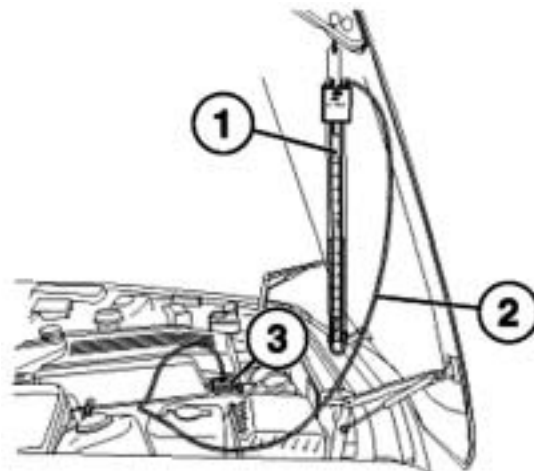

12550002

Fuel Management

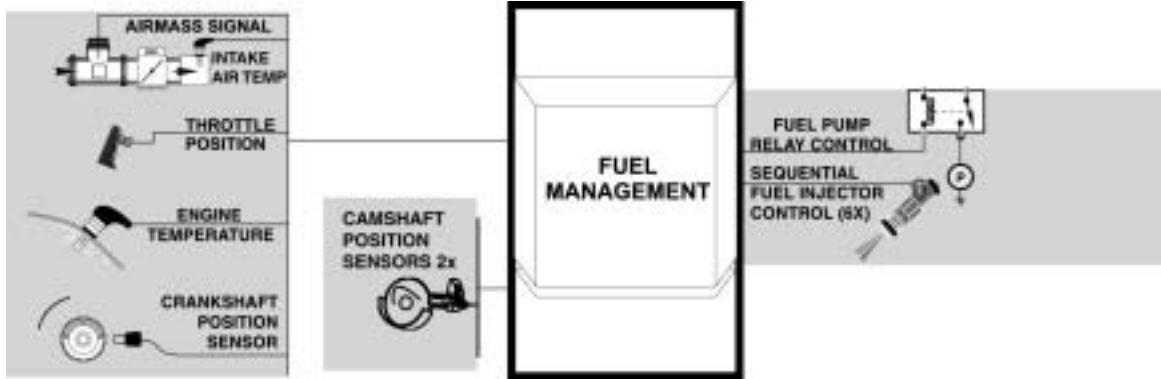

Fuel Tank: The fuel tank is made of high density polyethylene (reduced weight) which is manufactured to meet safety requirements.

A mid-chassis mounted “saddle” type tank is used providing a tunnel for the driveshaft but creates two separate lower chambers.

1. Ventilation line
2. Filler tube
3. Operating vent valve
4. Fuel pump assembly
5. Filling vent valve
6. Left fuel level sensor
7. Left syphon jet
8. Overpressure protection valve
9. Fuel filter and fuel pressure regulator
10. Anti-chafing pads (foam cushion)

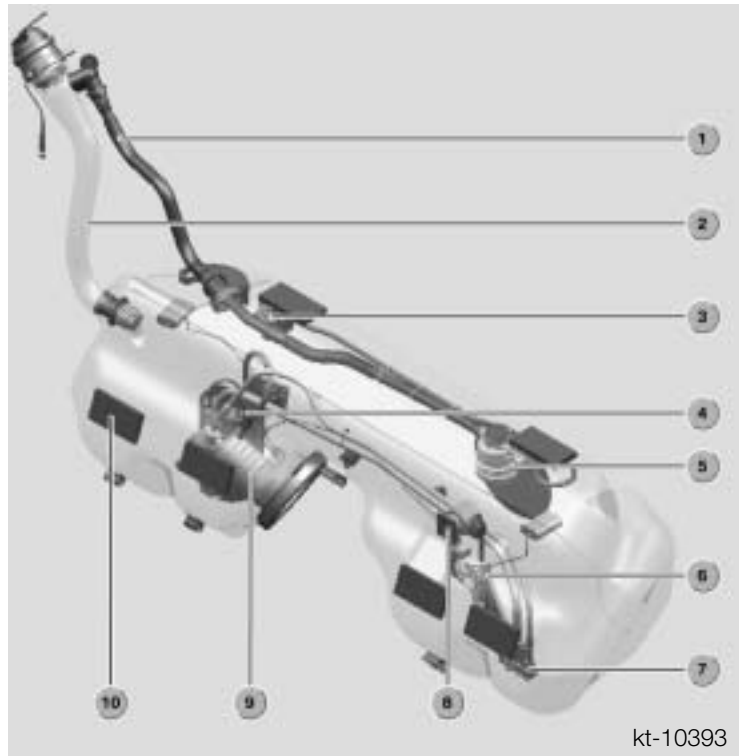

A syphon jet is required with this type of tank to transfer fuel from the left side, linked to the fuel return line. As fuel moves through the return, the syphon jet creates a low pressure (suction) to pick up fuel from the left side of the tank and transfer it to the right side at the fuel pick up.

The fuel tank capacity is 55 liters (14.5 gallons). This includes a reserve capacity of 8 liters (2 gal.).

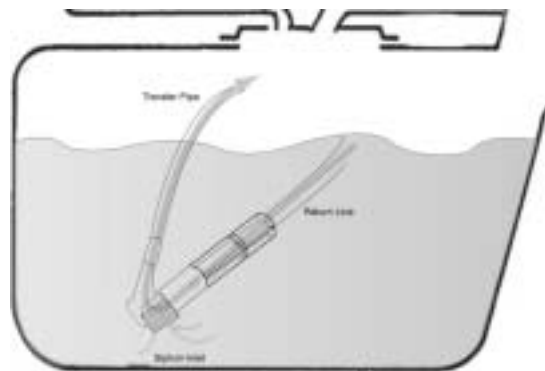

Detailed View of Syphon Jet

16550030

The E85 fuel tank design represents the next step in reducing the potential evaporative emissions. This design reduces the number of external connections and openings by increasing the amount of “in tank” or integral components. The fuel system is divided into two subsystems: fuel supply and fuel ventilation (evaporative containment and control - refer to Emissions Management section).

MS45 Fuel Supply:

1. Filler cap and tank grounding
2. Filler tube
3. Slosh baffle (anti-spitback valve)
4. Fuel tank
5. Baffle chamber with right fuel level sensor
6. Electric fuel pump (EKP)
7. Right syphon jet
- 8. Service access cap with fuel filter**
9. Fuel pressure regulator (3.5 bar)
10. Left syphon jet
11. Fuel supply line
12. Injection rail

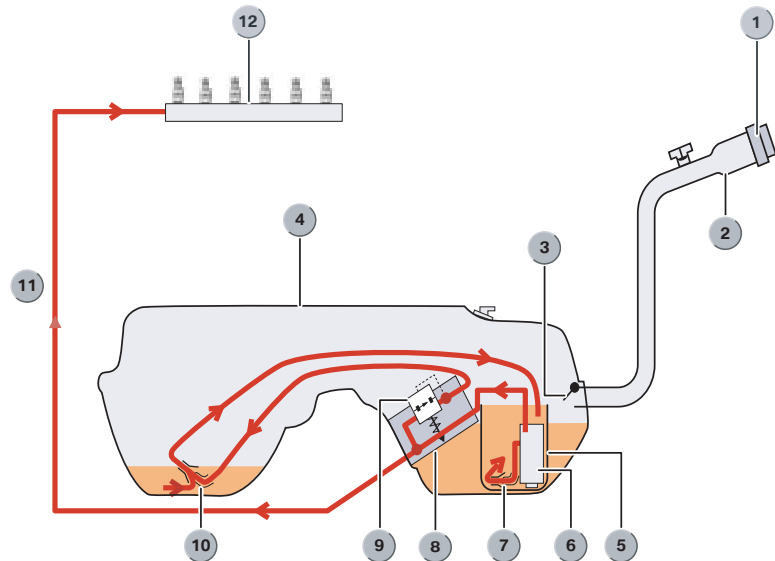

kt-10749

When the fuel pump is energized, it supplies fuel from the pickup area in the baffle chamber through the fuel filter to the fuel pressure regulator. The fuel supply pressure is controlled by the **3.5 Bar fuel pressure regulator** (integrated in the fuel filter assembly). The regulator is influenced by internal fuel pressure and not intake manifold vacuum. The fuel exits the fuel pressure regulator supplying the fuel rail and the injectors. The fuel rail distributes an even supply of fuel to all of the injectors, and also serves as a volume reservoir.

The fuel is supplied through a Non Return Fuel Rail System. The fuel return line is located on the filter/regulator assembly which directs the unused fuel back through the fuel tank. The fuel tank hydrocarbons are reduced by returning the fuel from this point (lower temperatures) instead of from the fuel rail.

As fuel moves through the return, the syphon jet creates a low pressure (suction) to pick up fuel from the left side of the tank and transfer it to the right side at the fuel pick up. A second syphon jet is mounted through the baffle chamber to draw as much fuel as possible from the right side of the tank into the baffle chamber (critical for low fuel or reserve situations).

Fuel Pump: The electric fuel pump supplies constant fuel volume to the injection system. This system uses a single submersible (in the fuel tank) pump. The inlet is protected by a mesh screen.

When the fuel pump is powered, the armature will rotate the impeller disc creating low pressure at the inlet. The fuel will be drawn into the inlet and passed through the fuel pump housing (around the armature). The fuel lubricates and cools the intervals of the pump motor.

The fuel will exit through a non-return check valve to supply the injection system. The non-return check valve is opened by fuel exiting the pump and will close when the pump is deactivated. This maintains a “prime” of fuel in the filter, lines, hoses and fuel rail.

The pump contains an internal overpressure relief valve that will open (reducing roller cell pressure) if there is a restriction in the fuel supply hardware.

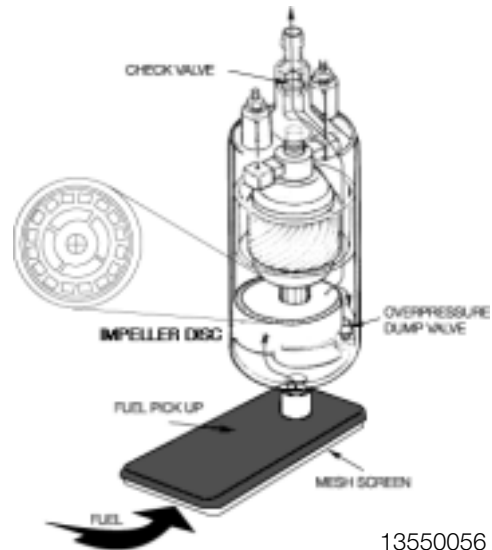

13550056

Fuel Supply Components: The fuel is transferred from the fuel pump to the fuel filter. The fuel filter “traps” contaminants before they reach the fuel injectors and should be replaced at the specified interval. The large filter size also serves as a volume reservoir (dampening fuel pump pulsations).

Fuel Pressure Regulator: The Fuel Pressure Regulator maintains a constant pressure for the fuel injectors. The fuel pressure is set to **3.5 bar** by internal spring tension on the restriction valve. The fuel pressure regulator is not influenced by vacuum.

The ECM determines the fuel quantity compensation for manifold vacuum changes. This is based on throttle position, HFM and load for precise compensation.

When the restriction valve opens, unused fuel returns from the regulator/filter assembly back through the fuel tank to the left side syphon jet.

Siemens Fuel Injectors: The Fuel Injectors are electronically controlled solenoid valves that provide precise metered and atomized fuel into the engine intake ports. The Fuel Injector Valve consists of:

1. Fuel Strainer
2. Electrical Connector
3. Solenoid Winding
4. Closing Spring
5. Solenoid Armature
6. Needle Valve
7. Pintle

Fuel is supplied from the fuel rail to the injector body. The fuel is channeled through the injector body to the needle valve and seat at the tip of the injector. Without electrical current, the needle valve is sprung closed against the seat.

The Fuel Injectors receive voltage from the Fuel Injector Relay. The ECM activates current flow through the injector solenoid creating a magnetic field that pulls the needle “up” off of its seat. The pressurized fuel flows through the tip of the injector that is fitted with a directional angle "plate" with dual outlets. This “fans out” the spray into an angled patterns which helps to atomize the fuel. When the ECM deactivates current flow, the needle valve is sprung closed against the seat and fuel flow through the injector is stopped. The lower portion of the injector body is jacketed in metal.

The length of time that the ECM activates the Fuel Injectors is very brief, the duration is in milli-seconds (ms). This affects the amount of fuel volume flowing through the Fuel Injectors. The ECM will vary the length of time (ms) to regulate the air/fuel ratio (mixture).

A Fuel Injector is faulty (mechanical or electrical), it can produce the following complaints:

- Malfunction Indicator Light
- Excessive Tailpipe smoke (leaking)
- Engine Hydrolock (leaking)
- Misfire/Rough Idle (Leaking or Blocked)
- Long Crank Time (Leaking)
- Oxygen Sensor/Mixture/Injector Related Fault Code



Crankshaft Position/RPM Sensor (Hall Effect): This sensor provides the crankshaft position and engine speed (RPM) signal to the ECM for fuel pump and Injector operation.

A Hall sensor is mounted on the left side at the rear of the engine block. The impulse wheel is mounted on the crankshaft inside the crankcase, at the rear main bearing support. The impulse wheel contains 58 teeth with a gap of two missing teeth.

The Hall sensor is supplied with voltage from the ECM. A digital square wave signal is produced by the sensor as the teeth of the impulse wheel pass by. The “gap” allows the ECM to establish crankshaft position.

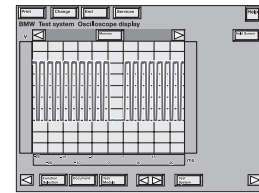
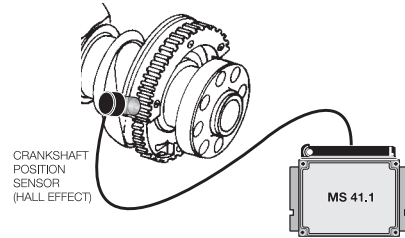

SMOOTH RUNNING ENGINE (NOTE SQUARE WAVE SIGNAL) 135500020

The crankshaft position sensor is monitored as part of OBD II requirements for Misfire Detection. If this input is faulty, the ECM will operate the engine (limited driveability) from the Camshaft Sensor input. A fault with this input will produce the following complaints:

- Hard Starting/Long Crank Time
- “Malfunction Indicator Light”
- Driveability/Misfire/Engine Stalling

Camshaft Sensors - Intake and Exhaust Camshafts

The "static" Hall sensors are used so that the camshaft positions are recognized once ignition is on (KL15) before the engine is started. The function of the intake cam sensor is:

- Cylinder “work cycle” for injection timing
- Synchronization
- Engine speed sensor (if crankshaft speed sensor fails)
- VANOS position control of the intake cam

The exhaust cam sensor is used for VANOS position control of the exhaust cam. If these sensors fail there are no substitute values, the system will operate in the failsafe mode with no VANOS adjustment. The engine will still operate, but torque reduction will be noticeable.

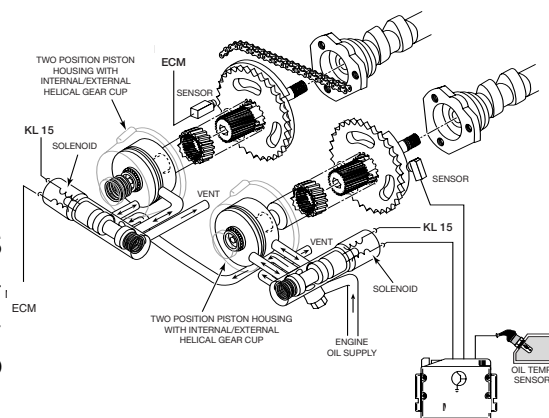

NOTE: Use caution on repairs as not to bend the impulse wheels.

Engine Coolant Temperature: The Engine Coolant Temperature is provided to the ECM from an NTC type sensor located in the coolant jacket of the cylinder head (left rear). The sensor contains two NTC elements, the other sensor is used for the instrument cluster temperature gauge.

The ECM determines the correct air/fuel mixture required for the engine temperature by monitoring an applied voltage to the sensor (5v). This voltage will vary (0-5v) as coolant temperature changes the resistance value.

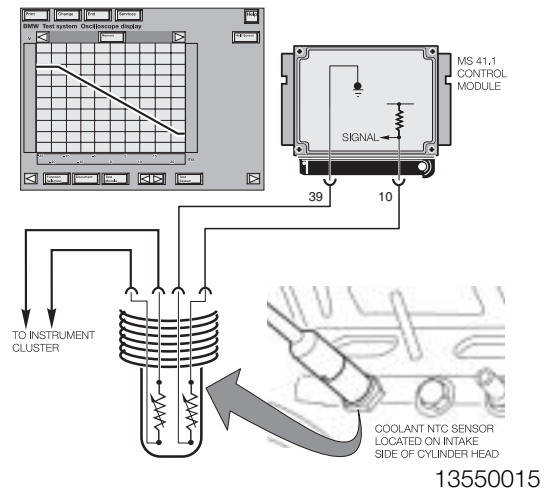

If the Coolant Temperature Sensor input is faulty, a fault code will be set the ECM will assume a substitute value (80° C) to maintain engine operation.

Throttle Position: For details about the sensor, refer to the Air Management section. As the throttle is opened, the ECM will increase the volume of fuel injected into the engine. As the throttle plate is closed, the ECM activates fuel shut off if the rpm is above idle speed (coasting).

Hot-Film Air Mass Meter (HFM): The air volume input signal is used by the ECM to determine the amount of fuel to be injected for correct air/fuel ratio. For details about the sensor, refer to the Air Management section.

Air Temperature: This signal allows the ECM to make a calculation of air density. For details about the sensor, refer to the Air Management section.

The varying voltage input from the NTC sensor indicates the larger proportion of oxygen found in cold air, as compared to less oxygen found in warmer air. The ECM will adjust the amount of injected fuel because the quality of combustion depends on oxygen sensing ratio.

Principle of Operation

Fuel Management delivers fuel from the tank to the intake ports of the engine. To accomplish this, **fuel supply** must be available to the fuel injectors. Then the fuel must be **injected** in the precise amount and at the correct time. The ECM does not directly monitor fuel supply, although it does control fuel supply. **The Fuel Pump** supplies fuel when it receives operating voltage from the Engine Control Module Relay supplying the Fuel Pump Relay. The ECM controls and monitors **fuel injection**.

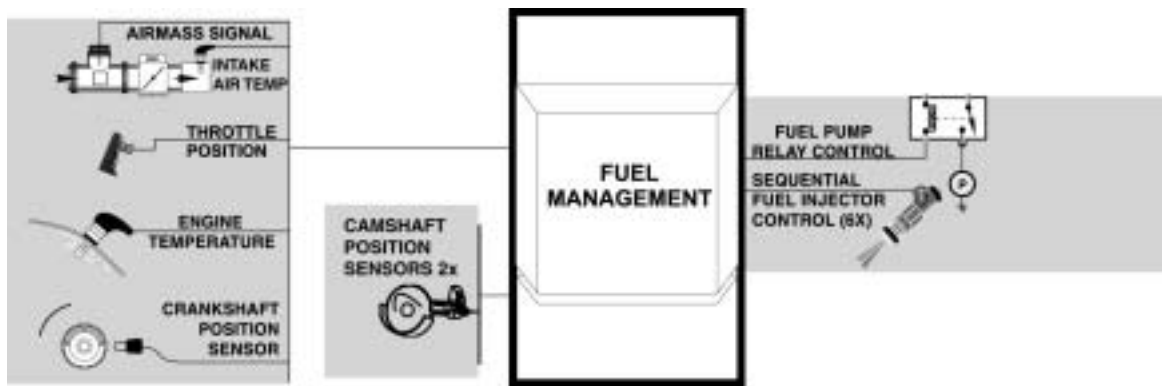

45-02-04

The Fuel Pump will be activated when the ignition (KL15) is switched “on” and the ECM supplies a ground circuit to activate the Fuel Pump Relay. The Fuel Pump Relay supplies operating power to the in-tank mounted fuel pump. This is a momentary activation to “pressurize” (prime) the fuel system.

The ECM then requires an engine speed signal from the Crankshaft Position/RPM Sensor to maintain continuous Fuel Pump Relay activation.

If the engine RPM signal is not present, the ECM will deactivate the Fuel Pump Relay.

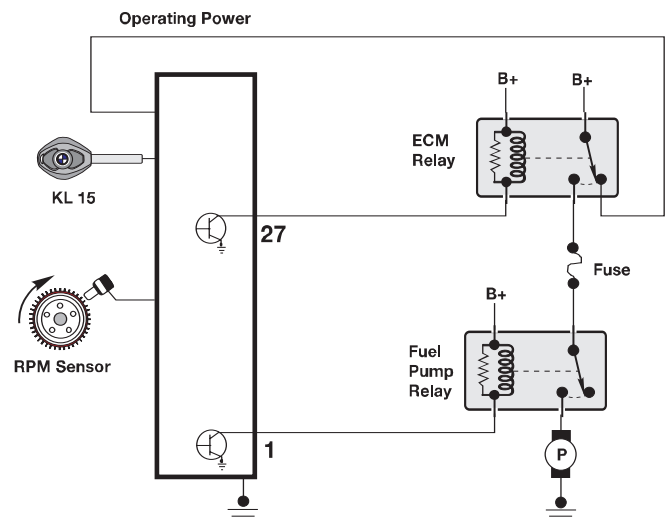

13550012

The Fuel Injectors will be opened by the ECM to inject pressurized fuel into the intake ports. The Fuel Injectors receive voltage from the Engine Control Module Relay. The ECM controls the opening by activating the ground circuits for the Solenoid Windings. The ECM will vary the duration (in milli-seconds) of “opening” time to regulate the air/fuel ratio.

The ECM has six Final Stage output transistors that switch ground to the six injector solenoids. The Injector “triggering” is first established from the Crankshaft Position/RPM Sensor.

The ECM is programmed to activate the Final Stage output transistors once for every two revolutions of the crankshaft in two groups (Semi-Sequential Injection).

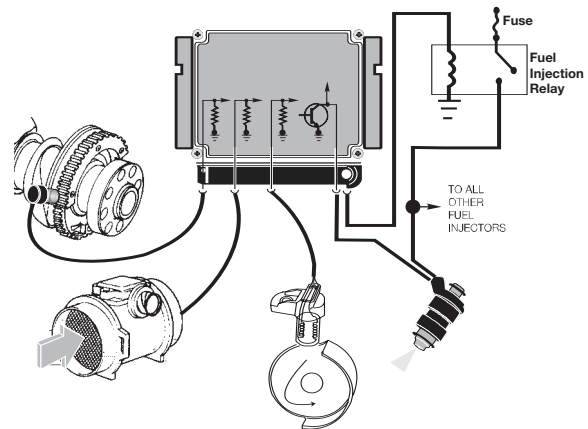

13550017

The injectors are opened in two groups for every complete “working cycle” of the engine. This delivers the fuel charge for cylinders 1,5,3 during one revolution of the crankshaft and cylinders 6,2,4 during the second revolution of the crankshaft. This process enhances fuel atomization during start up.

Semi-Sequential Injection

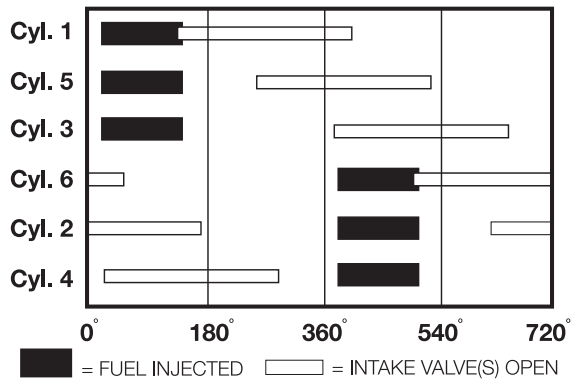

135500016

During start up, the ECM recognizes the Camshaft Position (Cylinder ID) input. The camshaft position is referenced to the crankshaft position. It then switches the injection to Full Sequential. This process “times” the injection closer to the intake valve opening for increased efficiency.

Full Sequential Injection

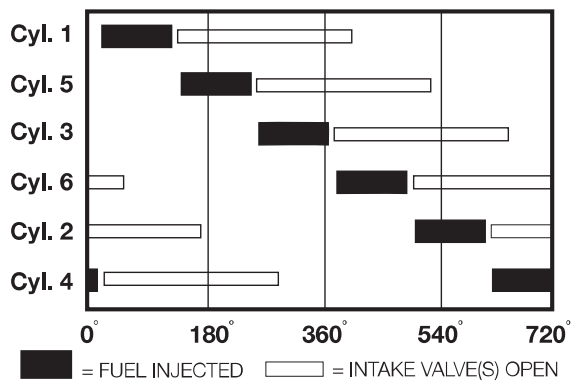

135500015

When activated, each injector delivers the full fuel charge at separate times during each engine working cycle.

If this input is faulty, the ECM will activate the injectors in Parallel to maintain engine operation and set a fault code.

The Injector “open” Time to maintain engine operation after it has been started is determined by the ECM (programming). The ECM will calculate the injection “timing” based on a combination of the following inputs:

- Battery Voltage
- Throttle Position
- Air Flow Volume/Mass
- Air Temperature
- Crankshaft Position/RPM
- Camshaft Position (Cylinder ID)
- Engine Coolant
- Oxygen Sensor
(Detailed in Emissions)

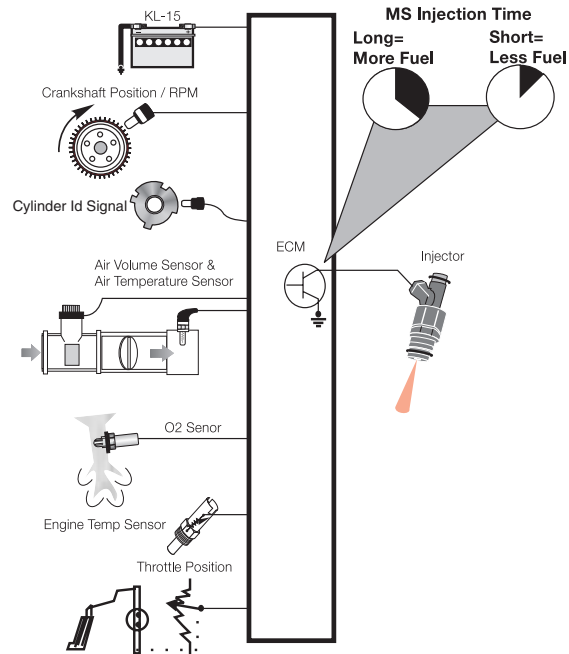

13550014

The injection ms value will be regulated based on battery voltage. When cranking, the voltage is low and the ECM will increase the ms value to compensate for injector “lag time”. When the engine is running and the battery voltage is higher, the ECM will decrease the injection ms value due to faster injector reaction time.

Cold starting requires additional fuel to compensate for poor mixture and the loss of fuel as it condenses onto cold intake ports, valves and cylinder walls. The cold start fuel quantity is determined by the ECM based on the Engine Coolant Temperature Sensor input during start up.

During cranking, additional fuel is injected (in Semi-Sequential) for the first few crankshaft revolutions. After the first few crankshaft revolutions, the injected quantity is metered down as the engine comes up to speed. When the engine speed approaches idle rpm, the ECM recognizes the Camshaft Position and switches to Full Sequential injection.

When the engine is cold, optimum fuel metering is not possible due to poor air/fuel mixing and an enriched mixture is required. The Coolant Temperature input allows the ECM to adjust the injection ms value to compensate during warm up and minimize the the injected fuel at engine operating temperature.

When the engine is at idle, minimum injection is required. Additional fuel will be added if the ECM observes low engine rpm and increasing throttle/air volume inputs (acceleration enrichment). As the throttle is opened, the ECM monitors acceleration and rate of movement. The ECM will increase the volume of fuel injected into the engine by increasing the injection ms value. The “full throttle” position indicates maximum acceleration and the ECM will add more fuel (full load enrichment).

As the throttle is closed, the ECM decreases the injection ms value (fuel shut off) if the rpm is above idle speed (coasting). This feature decreases fuel consumption and lowers emissions. When the engine rpm approaches idle speed, the injection ms value is increased (cut-in) to prevent the engine from stalling. The cut-in rpm is dependent upon the engine temperature and the rate of deceleration.

The Hot-Film Air Mass (HFM) signal provides the measured amount of intake air volume/mass. This input is used by the ECM to determine the amount of fuel to be injected to “balance” the air/fuel ratio.

The Air Temperature Signal allows the ECM to make an additional calculation of air density. The varying voltage input from the NTC sensor indicates the larger proportion of oxygen found in cold air, as compared to less oxygen found in warmer air. The ECM will adjust the amount of injected fuel because the quality of combustion depends on oxygen sensing ratio (details in Emissions).

The Crankshaft Position/RPM signals the ECM to start injection as well as providing information about the engine operation. This input is used in combination with other inputs to determine engine load which increases/decreases the injection ms value. Without this input, the ECM will not activate the injectors.

The Camshaft Position (Cylinder ID) affects the injection timing (Semi-Sequential/Full Sequential). To accomplish this, the ECM contains six Final Stage output transistors that activate the injectors individually. The engine operates sufficiently on Semi-Sequential Injection (two groups of three), but more efficiently on Full Sequential Injection (six individual). If one of the fuel injector circuits faulted, the engine can still operate on limited power from the other remaining fuel injector circuits.

Injection “Reduction” Time is required to control fuel economy, emissions, engine and vehicle speed limitation. The ECM will “trim” back or deactivate the fuel injection as necessary while maintaining optimum engine operation.

As the throttle is closed during deceleration, the ECM decreases the injection ms value (fuel shut off) if the rpm is above idle speed (coasting). This feature decreases fuel consumption and lowers emissions.

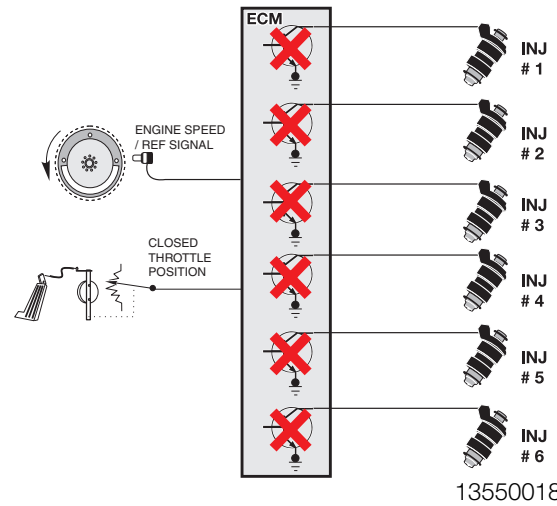

When the engine rpm approaches idle speed, the injection ms value is increased (cut-in) to prevent the engine from stalling. The cut-in rpm is dependent upon the engine temperature and the rate of deceleration. This function can be observed as displayed on the Fuel Economy (MPG) gauge.

The ECM will selectively deactivate injectors to control maximum engine rpm (regardless of vehicle speed). When the engine speed reaches 6500 rpm, the injectors will be individually deactivated as required to protect the engine from over-rev.

As the engine speed drops below 6500 rpm, injector activation will be resumed. **This feature does not protect the engine from a forced over-rev such as improperly downshifting a manual transmission equipped vehicle (driver error).**

Maximum vehicle speed is also limited by the ECM selectively deactivating the injectors (regardless of engine rpm).

This limitation is based on the vehicle dimensions, specifications and installed tires (speed rating).

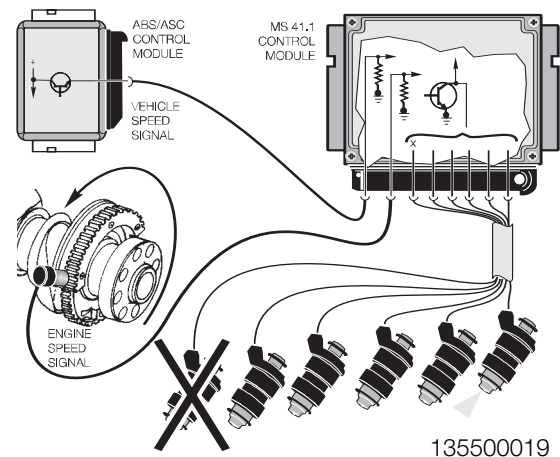

The ECM will also protect the Catalytic Converter by deactivating the injectors.

If the ECM detects a “misfire” (ignition, injection or combustion) it can selectively deactivate the Final Stage output transistor for that cylinder(s).

The injector(s) will not open, preventing unburned fuel from entering the exhaust system.

On the MS45 system, there are six individual injector circuits resulting in deactivation of one or multiples. This will limit engine power, but protect the Catalytic Converter.

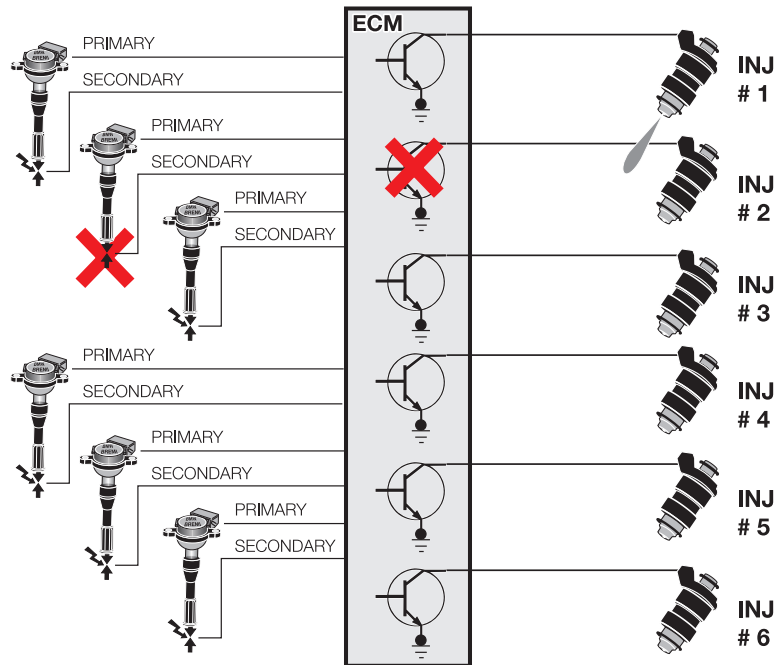

135500022

Fuel Injection Control Monitoring is performed by the ECM for OBD II requirements. Faults with the fuel injectors and/or control circuits will be stored in memory. This monitoring includes:

- Closed Loop Operation
- Oxygen Sensor Feedback

These additional corrections are factored into the calculated injection time. If the correction factor exceeds set limits a fault will be stored in memory.

When the criteria for OBD II monitoring is achieved, the “Malfunction Indicator Light” will be illuminated.

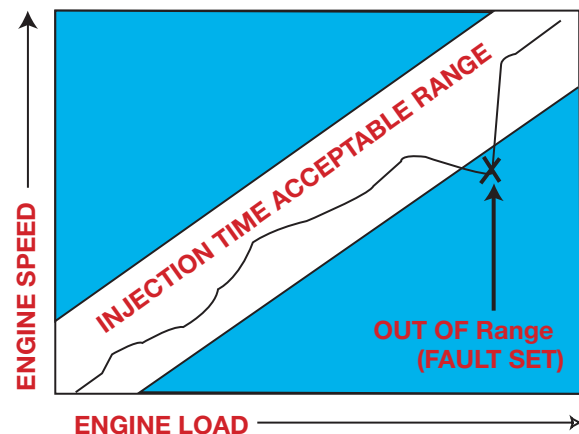

13550010

Workshop Hints

Before any service work is performed on any fuel system related component, always adhere to the following:

- Observe relevant safety legislation pertaining to your area.
- Ensure adequate ventilation.
- Use exhaust extraction system where applicable (alleviate fumes).
- **DO NOT OPERATE THE FUEL PUMP** unless it is properly installed in the fuel tank and is submersed in the fuel (fuel lubricates the pump).
- Always wear adequate protection clothing including eye protection.
- Use caution when working around a hot engine compartment
- During fuel system repair that involves “sealing rings”, always replace them with a new **COPPER** rings only.
- BMW does not recommend any **UNAUTHORIZED MODIFICATIONS** to the fuel system. The fuel system are designed to comply with strict federal safety and emissions regulations. In the concern of product liability, it is unauthorized to sell or perform modifications to customers vehicles, particular in safety related areas.
- Always consult the Repair Instructions on the specific model you are working on before attempting a repair.

Fuel

Fuel quality should always be considered when diagnosing a driveability complaint. The type of fuel, proper AKI rating, impurities and moisture ***are not factored by the ECM.***

Please refer to the Owner’s Manual and following Service Information Bulletins regarding fuel:

- Gasoline Fuel Quality S.I. #13 01 88 (1564)
- Gasoline Additive S.I. #13 04 88 (1591)

Fuel Supply

The fuel supply hardware should be visually inspected for damage that can affect pick-up, transfer, pressure and return. Please refer to the Repair Instructions for details on fuel supply hardware.

Fuel Filter, Pressure Regulator, Pump and Sending Unit Access

Caution! The fuel tank must be drained first before removing the Service access cap to perform any repair attempts.

Consult the Repair Instructions for additional details and updated information.

1. Fuel tank
2. Service access cap

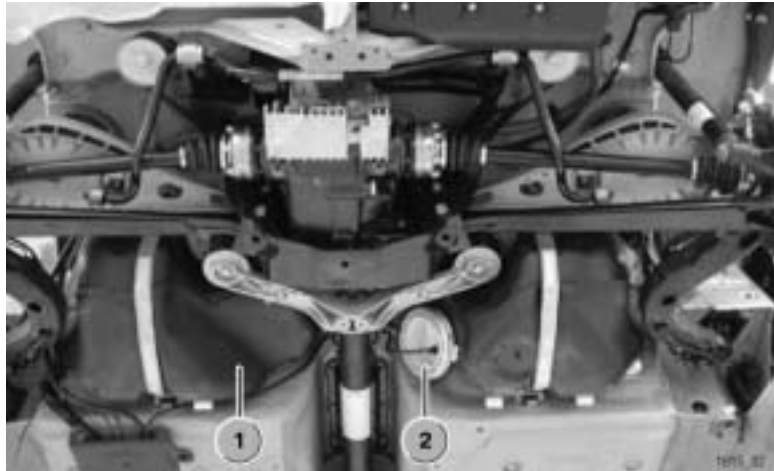

kt-10392

The fuel filter, fuel pressure regulator, electric fuel pump, right fuel level sensor and syphon jet are accessed through the “Service access cap”. Remove the single 6 pin electrical connector (2 pins for the fuel pump, 2 for each level sensor - left/right). Remove the fuel supply line by releasing the “quick” release coupling.

The fuel tank is secured by two straps to the body.

The Fuel Injectors should also be tested using the DISplus/GT1 for:

- Resistance
- Power Supply
- Status Display - Fuel Injection Signal
- ECM Final Stage transistor activation. This test functions is found under the oscilloscope Preset list - "Ti Injection Signal". Install the Universal Adapter, Diagnostic cable, MFK 2 negative lead to ECM ground and MFK 2 positive lead to the ground activation circuit for the injector. This test is performed with the engine cranking or running.

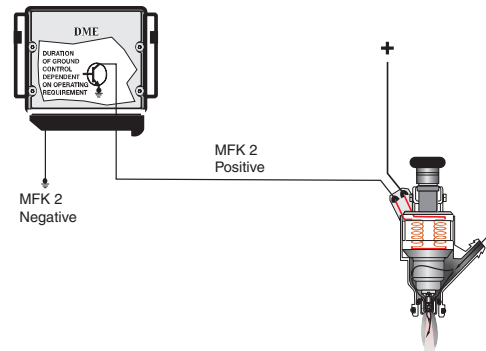

16550018

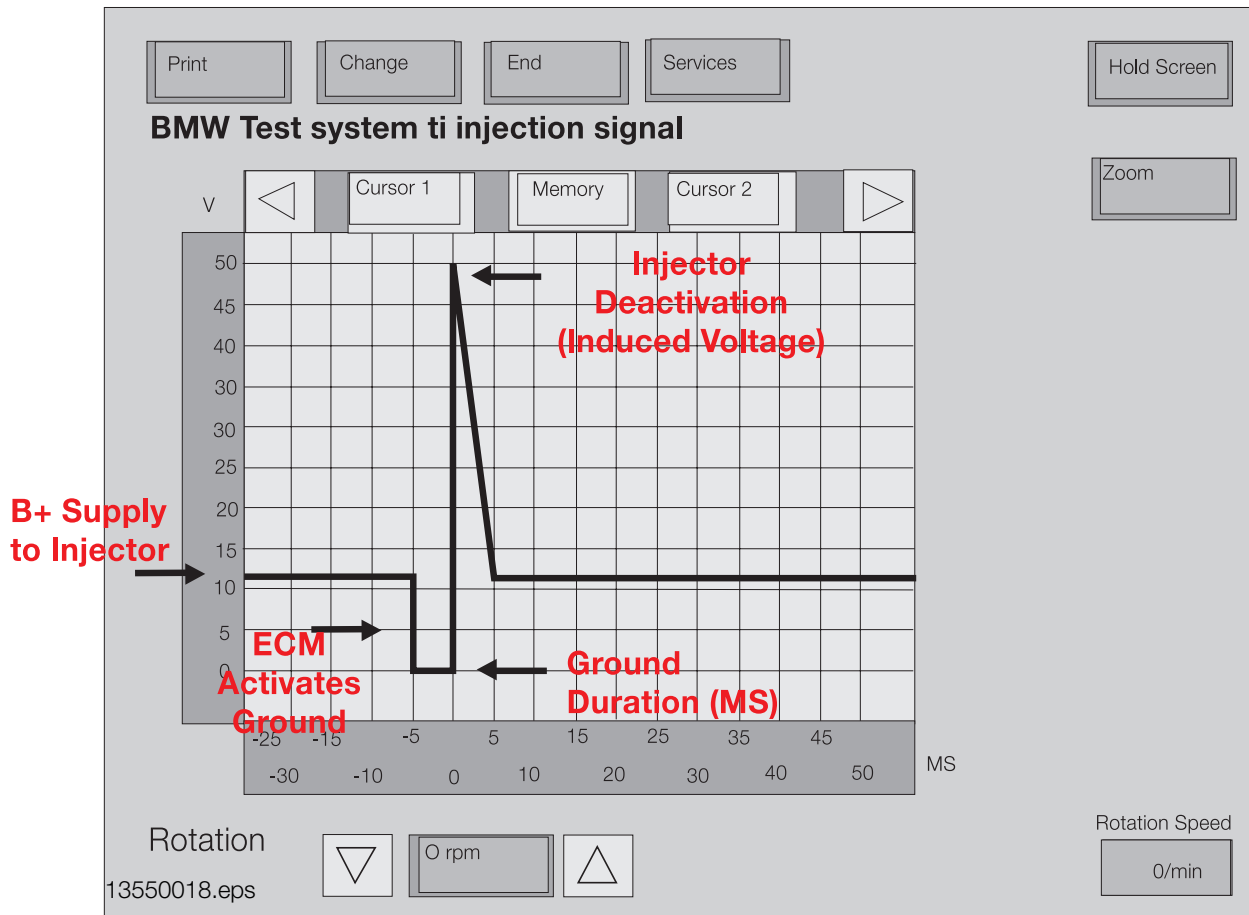

13550018

Crankshaft Position/RPM Sensor

This sensor should be tested using the DISplus/GT1 for:

- Power Supply
- DC Voltage
- Status Display
- Oscilloscope Display found under Preset Measurements - "Engine Speed Sensor Signal"

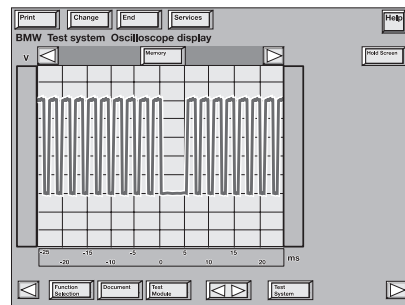
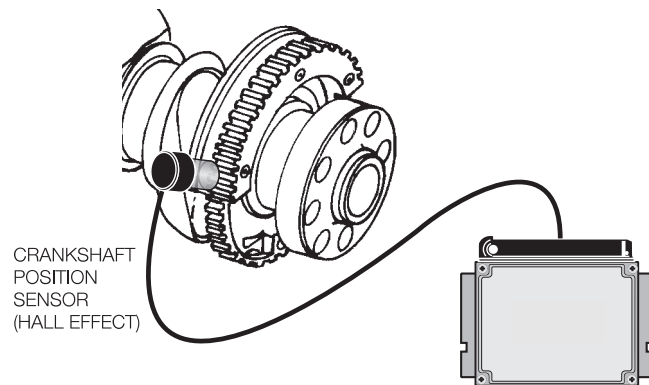

**SMOOTH RUNNING ENGINE
(NOTE SQUARE WAVE SIGNAL)**

135500020

Engine Coolant Temperature

NTC sensors decrease in resistance as the temperature rises and vice versa. The ECM monitors the sensor voltage which varies as temperature changes the resistance value. For example, as temperature rises:

- Resistance through the sensor decreases
- Voltage drop of the sensor decreases
- Input signal voltage also decreases (5-0v)

The Sensor should be tested using:

- DISplus/GT1 Multimeter degrees C (dependent on engine temperature).
- DISplus/GT1 Multimeter ECM input 2.250K ohms at 20° C Temp. Gauge input 6.7 k ohms at 20° C Temperature. Gauge input 6.7 K ohms at 20° C.

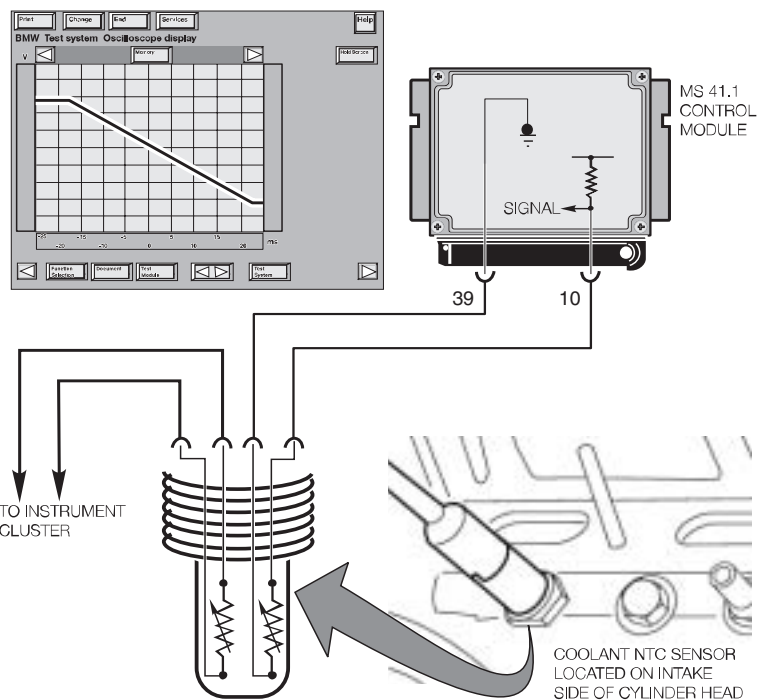

13550015.eps

Tools and Equipment

The DISplus/GT1 as well as a reputable hand held multimeter can be used when testing inputs/components.

It is best to make the checks at the ECM connection, this method includes testing the wiring harness.

The correct Universal Adapter for the MS45 application should be used (#90 88 6 121 300). This will ensure the pin connectors and the harness will not be damaged.

When installing the Universal Adapter to the ECM (located below the windshield on the passenger side of the engine compartment), make sure the ignition is switched off.

NOTE for MS45: Allow at least 3 minutes to elapse after the key was set to the "OFF" position before disconnecting the ECM/ TCM.

This will allow sufficient time to complete the DM TL test. Voltage may be present (up to 3 minutes) causing damage to the ECM/TCM if they are disconnected during this time period (arcing).

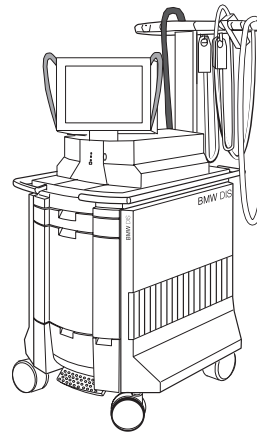

DISplus



GT-1

16550019

SKE BREAKOUT BOX SET
P/N 90 88 6 121 300

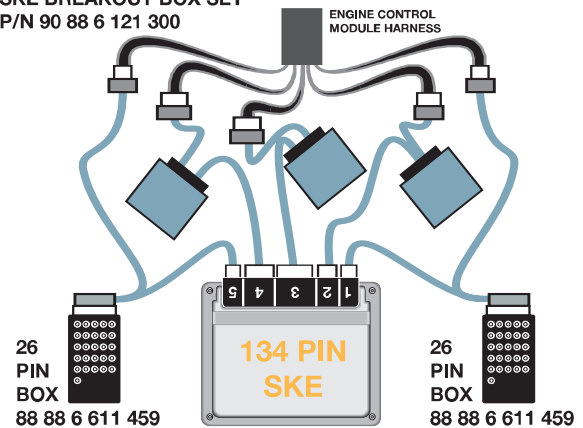

16550020

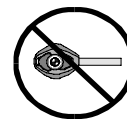

Ignition Management

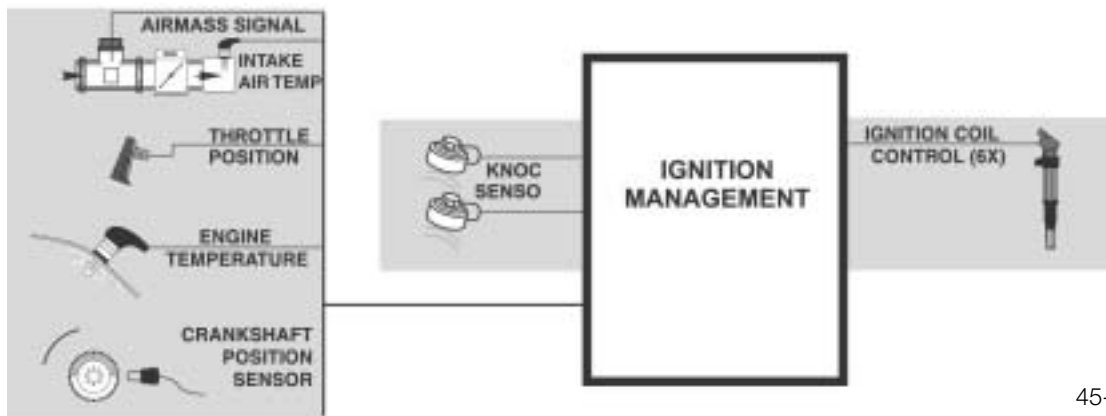

Ignition Coils: The high voltage supply required to ignite the mixture in the combustion chambers is determined by the stored energy in the ignition coils. The stored energy contributes to the ignition duration, ignition current and rate of high voltage increase. The Coil circuit including primary and secondary components consists of:

1. Coil Assembly
 - Primary Winding
 - Secondary Winding
2. Boot Connector
3. Spark Plug
4. ECM Final Stage Transistor

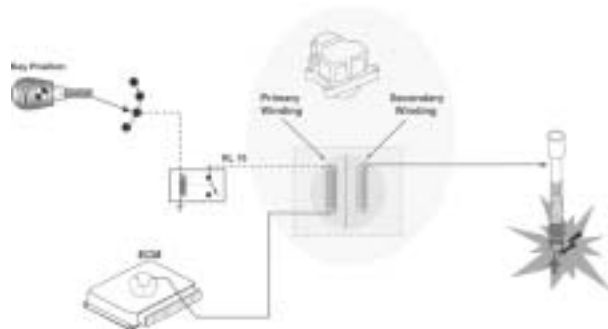

The Coil Assembly contains two copper windings insulated from each other. One winding is the primary winding, formed by a few turns of thick wire. The secondary winding is formed by a great many turns of thin wire.

The MS45 primary winding receives battery voltage from the ECM Main Relay which is activated by the ignition switch KL15 (Emission Optimized). The ECM provides a ground path for the primary coil (Terminal 1) by activating a Final Stage transistor. The length of time that current flows through the primary winding is the “dwell” which allows the coil to “saturate” or build up a magnetic field.

After this storage process, the ECM will interrupt the primary circuit at the point of ignition by deactivating the Final Stage transistor. The magnetic field built up within the primary winding collapses and induces the ignition voltage in the secondary winding.

The high voltage generated in the secondary winding is discharged through Coil Terminal 4 to the spark plug (insulated by the boot connector). The primary and secondary windings are un-coupled, therefore, the secondary winding requires a ground supply (Coil Terminal 4a).

There is an individual ignition circuit and coil for each cylinder on the MS45 system. The six individual ignition coils are integrated with the insulated connector (boot). The assemblies are mounted on top of the cylinder head cover.

The coils are removed by lifting the swivel latch connector retainer to release the wiring harness, apply a slight twist and lift the assembly upwards.

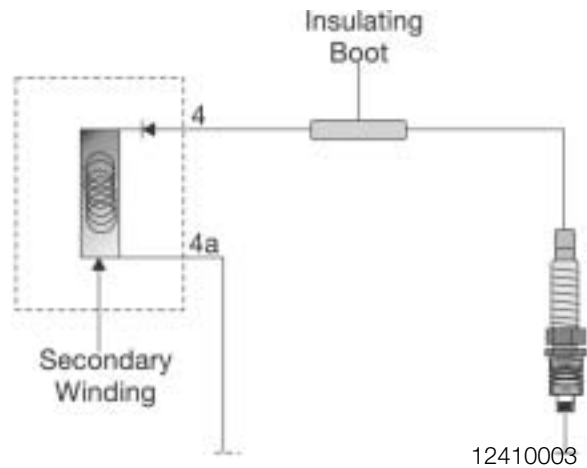

Spark Plugs: The spark plugs introduce the ignition energy into the combustion chamber. The high voltage “arcs” across the air gap in the spark plug from the positive electrode to the negative electrode. This creates a spark which ignites the combustible air/fuel mixture.

The spark plugs are located in the center of the combustion area (on the top of the cylinder head) which is the most suitable point for igniting the compressed air/fuel mixture.

Note: High Performance Platinum Spark Plugs are approved for use.

- NGK BKR6EQUP (quad electrode, non adjustable gap)

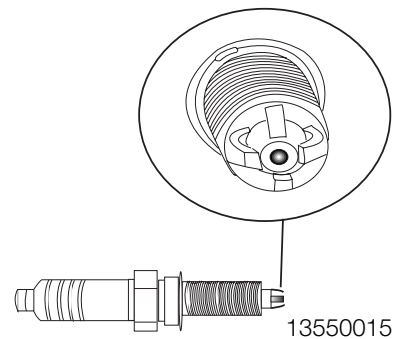

Faults with the Ignition Output Components are monitored by the ECM. If there are faults with the ignition coil(s) output and/or spark plugs, the following complaints could be encountered:

- “Malfunction Indicator Light” With Mixture Related Fault Codes
- Poor Engine Performance
- No Start/Hard Starting
- Excessive Exhaust Emissions/Black Smoke

The *ignition* is monitored by the ECM via the secondary ignition feedback circuit and Crankshaft Position/RPM Sensor. If a Misfire fault is present, the “Malfunction Indicator Light” will illuminate when the OBD II criteria is achieved and the ECM will deactivate the corresponding fuel injector for that cylinder. Engine operation will still be possible.

Knock Sensors: are required to prevent detonation (pinging) from damaging the engine. The Knock Sensor is a piezoelectric conductor-sound microphone. The ECM will retard the ignition timing (cylinder selective) based on the input of these sensors. Detonation can occur due to:

- High Compression Ratio
- Poor Quality Fuel (Octane Rating)
- High Level of Cylinder Filling
- Maximum Timing Advance Curve
- High Intake Air and Engine Temperature
- Carbon Build-Up (Combustion Chamber)

The Knock Sensor consists of:

1. Shield Wire
2. Cup Spring
3. Seismic Mass
4. Housing
5. Inner Sleeve
6. Piezo-Ceramic Element

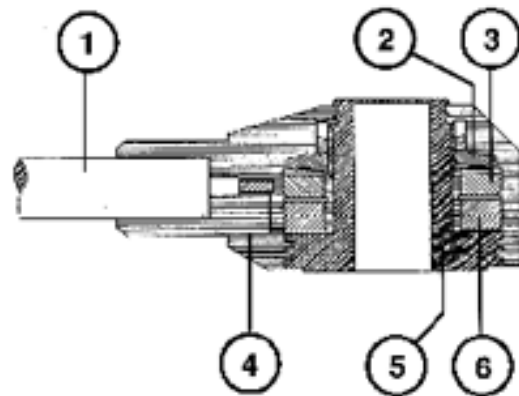

13550005

A piezo-ceramic ring is clamped between a seismic mass and the sensor body. When the seismic mass senses vibration (flexing), it exerts a force on the piezo-ceramic element. Opposed electrical charges build up on the upper and lower ceramic surfaces which generates a voltage signal. The acoustic vibrations are converted into electrical signals. These low voltage signals are transmitted to the ECM for processing.

There are two Knock Sensors bolted to the engine block on the intake manifold side, (1) between cylinders 1 - 3 and (2) between cylinders 4 - 6. If the signal value exceeds the threshold, the ECM identifies the “knock” and retards the ignition timing for that cylinder.

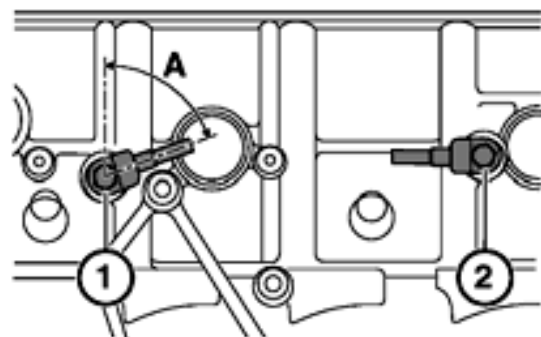

13550001

If a fault is detected with the sensor(s), the ECM deactivates Knock Control. The “Malfunction Indicator Light” will be illuminated when the OBD II criteria is achieved, the ignition timing will be set to a conservative basic setting and a fault will be stored.

Crankshaft Position/RPM Sensor: This sensor provides the crankshaft position and engine speed (RPM) signal to the ECM for ignition activation and correct timing. This input is also monitored for Misfire Detection. For details about the sensor, refer to the Fuel Management section.

A fault with this input will produce the following complaints:

- No Start
- Intermittent Misfire/Driveability
- Engine Stalling

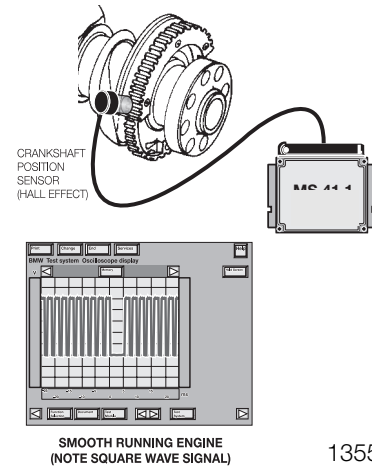

13550010

Camshaft Position Sensors (Cylinder Identification): The cylinder ID sensor input allows the ECM to determine camshaft position in relation to crankshaft position. It is used by the ECM to establish the “working cycle” of the engine for precise ignition timing. For details about the sensor, refer to the Fuel Management section.

If the ECM detects a fault with the Cylinder ID Sensor, the “Malfunction Indicator Light” will be illuminated when the OBD II criteria is achieved and the system will still operate precise single ignition based on the Crankshaft Position/RPM Sensor.

If the signal is impaired during a restart, the ECM will activate “*double ignition*”. The ignition coils will be activated on both the compression and exhaust strokes to maintain engine operation.

Engine Coolant Temperature: The ECM determines the correct ignition timing required for the engine temperature. For details about the sensor, refer to the Fuel Management section. This sensor is located in the coolant jacket of the cylinder head (left rear).

If the Coolant Temperature Sensor input is faulty, the “Malfunction Indicator Light” will be illuminated when the OBD II criteria is achieved and the ECM will assume a substitute value (80° C) to maintain engine operation. The ignition timing will be set to a conservative basic setting.

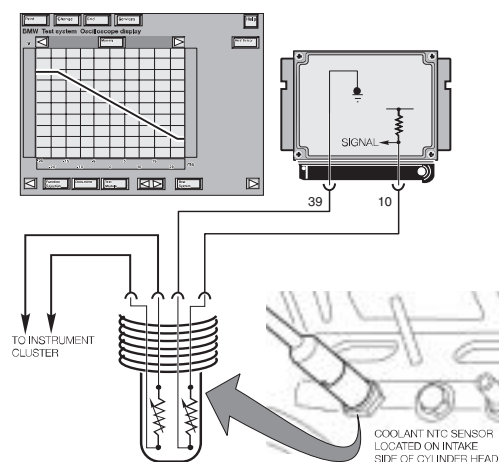

13550015

Hot-Film Air Mass Meter: This input is used by the ECM to determine the amount of ignition timing advance based on the amount of intake air volume. For details about the sensor, refer to the Air Management section.

If this input is defective, a fault code will be set and the “Malfunction Indicator Light” will illuminate when the OBD II criteria is achieved. The ECM will maintain engine operation based on throttle position and the Engine Speed Sensor, and the ignition timing will be set to a conservative basic setting.

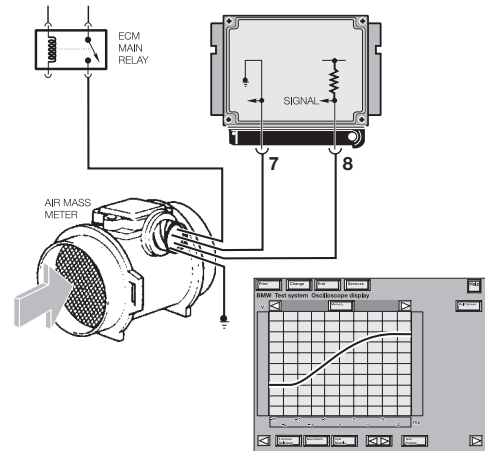

13550004

Throttle Position: This provides the ECM with accelerator pedal position and rate of movement. As the accelerator pedal is depressed the ECM will advance the ignition timing. The “full throttle” position indicates maximum acceleration to the ECM, the ignition will be advanced for maximum torque. For details about the sensor, refer to the Air Management section.

Air Temperature: This signal allows the ECM to make a calculation of air density. For details about the sensor, refer to the Air Management section.

The ECM will adjust the ignition timing based on air temperature. If the intake air is hot the ECM retards the ignition timing to reduce the risk of detonation. If the intake air is cooler, the ignition timing will be advanced.

If this input is defective, a fault code will be set and the “Malfunction Indicator Light” will illuminate when the OBD II criteria is achieved. The ignition timing will be set to a conservative basic setting.

Notes:

Principle of Operation

Ignition Management provides ignition to the combustion chambers with the required voltage at the correct time. Based on the combination of inputs, the ECM calculates and controls the **ignition timing** and **secondary output voltage** by regulating the activation and dwell of the **primary ignition circuits**. The ECM controls and monitors the secondary ignition output including **Misfire Detection**.

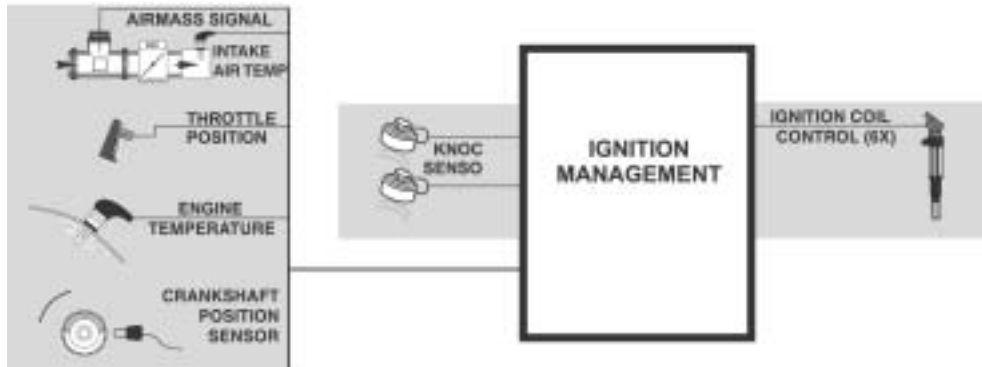

45-02-05

The ECM has a very “broad” range of ignition timing. This is possible by using a Direct Ignition System, or sometimes referred to as “Static Ignition System” (RZV). Reliability is also increased by having separate individual ignition circuits.

The Ignition Control is determined by the ECM (load dependent). The ECM will calculate the engine “load” based on a combination of the following inputs:

- Battery Voltage
- Accelerator Pedal Position
- Air Flow Volume
- Air Temperature
- Engine Coolant
- Crankshaft Position / RPM
- Camshaft Positions (Cylinder ID)
- Knock Sensors

The dwell time will be regulated based on battery voltage. When cranking, the voltage is low and the ECM will increase the dwell to compensate for saturation “lag time”. When the engine is running and the battery voltage is higher, the ECM will decrease the dwell due to faster saturation time.

The Crankshaft Position/RPM signals the ECM to start ignition in firing order (1-5-3-6-2-4) as well as providing information about the engine operation. This input is used in combination with other inputs to determine engine load which advances/retards the ignition timing. Without this input, the ECM will not activate the ignition.

Cold start is determined by the ECM based on the engine coolant temperature and rpm during start up. A cold engine will crank over slower than a warm engine, the ignition timing will range between top dead center to slightly retarded providing optimum starting.

When starting a warm engine, the rpm is higher which results in slightly advanced timing.

If the engine coolant and intake air temperature is hot, the ignition timing will not be advanced reducing starter motor "load".

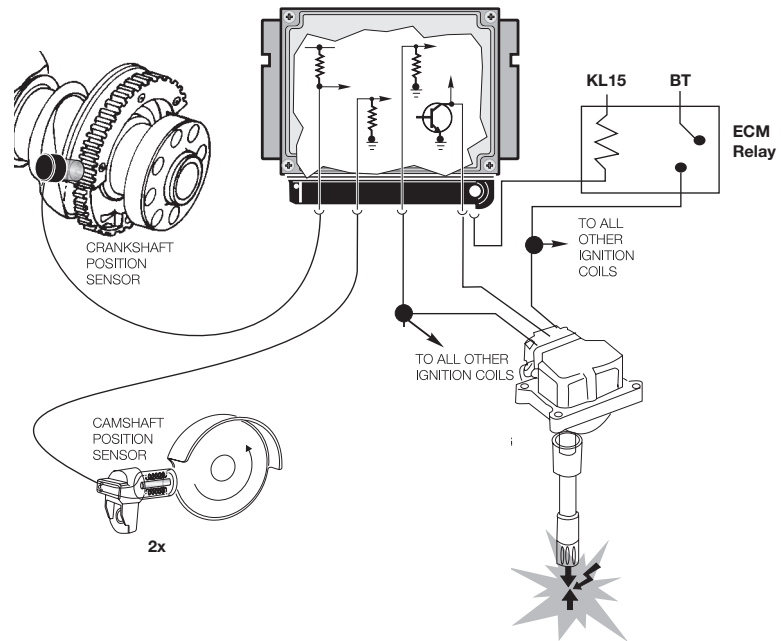

12550010

Multiple Ignition Pulses ensure good spark quality during engine start up. The ECM will activate the ignition coils 9 times (voltage dependent) per 720° of crankshaft revolution.

The ignition timing will be progressively advanced assisting the engine in coming up to speed. As the engine speed approaches idle rpm, the timing remains slightly advanced to boost torque. When the engine is at idle speed, minimum timing advance is required. This will allow faster engine and catalyst warm up.

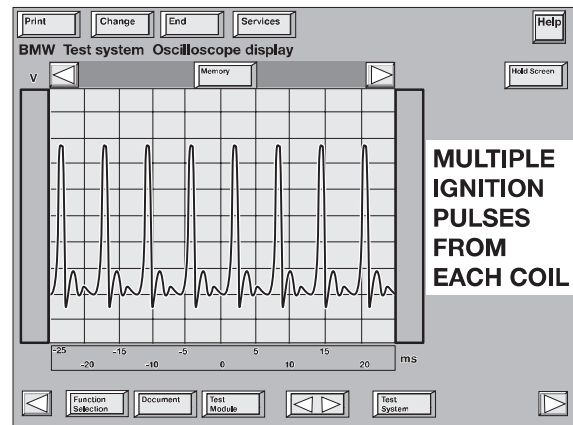

12550011

The multiple pulsing switches to single pulse when:

- Engine Speed >1350 RPM (varied with engine temperature)

The timing will be advanced when the ECM observes low engine rpm and increasing throttle/air volume inputs (acceleration torque). As the throttle is opened, the ECM advances the timing based on engine acceleration and at what rate. The ECM will fully advance timing for the "full throttle" position indicating maximum acceleration (torque).

MS45 Emission Optimized - Ignition Key Off

“Emission Optimized Ignition Key Off” is a programmed feature of the MS45 ECM.

After the ECM detects KL15 is switched “off”, the ignition stays active (ECM Relay/voltage supply) for two more individual coil firings.

This means that just two cylinders are fired - not two revolutions.

This feature allows residual fuel injected into the cylinders, as the ignition key is switched off, to be combusted as the engine runs down.

EMISSION OPTIMIZED IGNITION KEY OFF

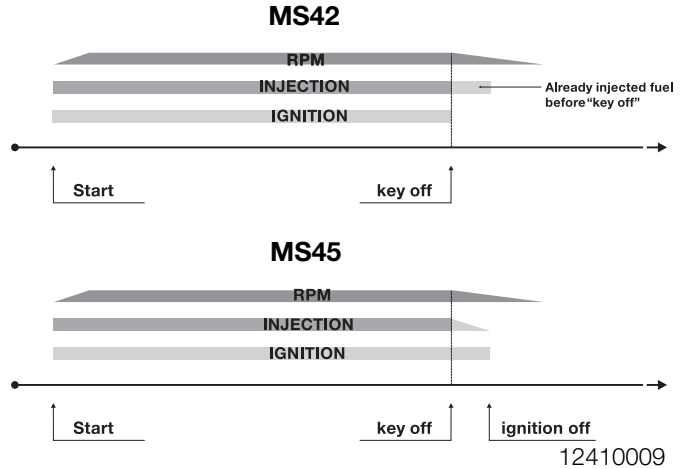

When *KL15* is switched “off” the ECM operating voltage is removed.

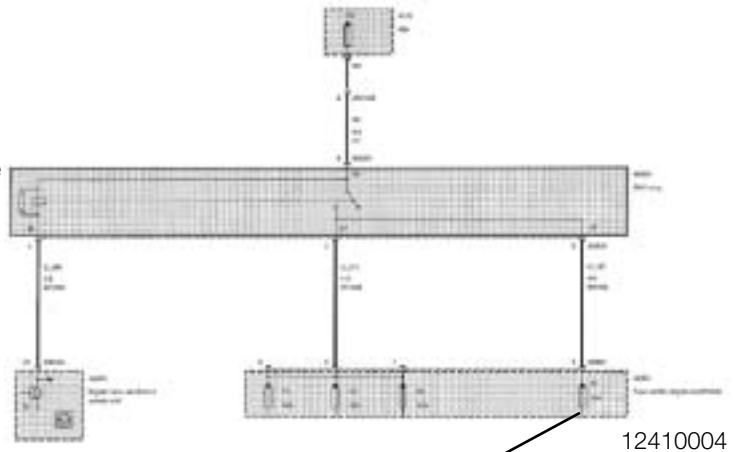

The ECM will maintain a ground to the Engine Control Module Relay for a few seconds to maintain ignition coil activation.

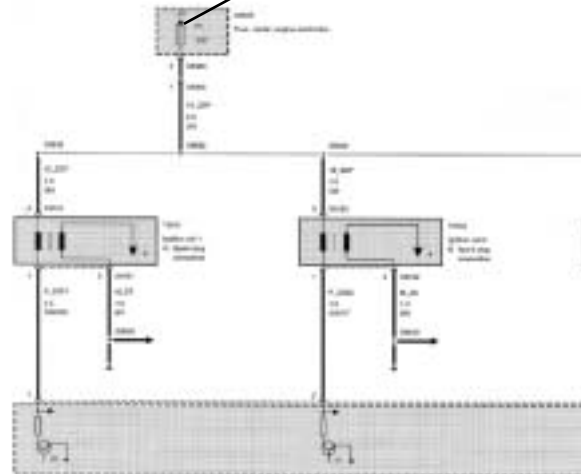

The HFM signal represents the amount of intake air volume. This input is used by the ECM to determine the amount of timing advance to properly combust the air/fuel mixture.

The Air Temperature Signal assists the ECM in reducing the risk of detonation (ping). If the intake air is hot the ECM retards the ignition timing. If the intake air is cooler, the ignition timing will be advanced.

As the throttle is closed, the ECM decreases the ignition timing if the rpm is above idle speed (coasting). This feature lowers the engine torque for deceleration. When the engine rpm approaches idle speed, the timing is slightly advanced to prevent the engine from stalling. The amount of advance is dependent upon the engine temperature and the rate of deceleration.

Knock Control allows the ECM to further advance the ignition timing under load for increased torque. This system uses two Knock Sensors located between cylinders 1,2,3 and between cylinders 4,5,6. Knock Control is only in affect when the engine temperature is greater than 35 °C and there is a load on the engine. This will disregard false signals while idling or from a cold engine.

Based on the firing order, the ECM monitors the Knock Sensors after each ignition for a normal (low) signal.

If the signal value exceeds the threshold, the ECM identifies the “knock” and retards the ignition timing (3°) for that cylinder the next time it is fired. This process is repeated in 3° increments until the knock ceases.

The ignition timing will be advanced again in increments to just below the knock limit and maintain the timing at that point.

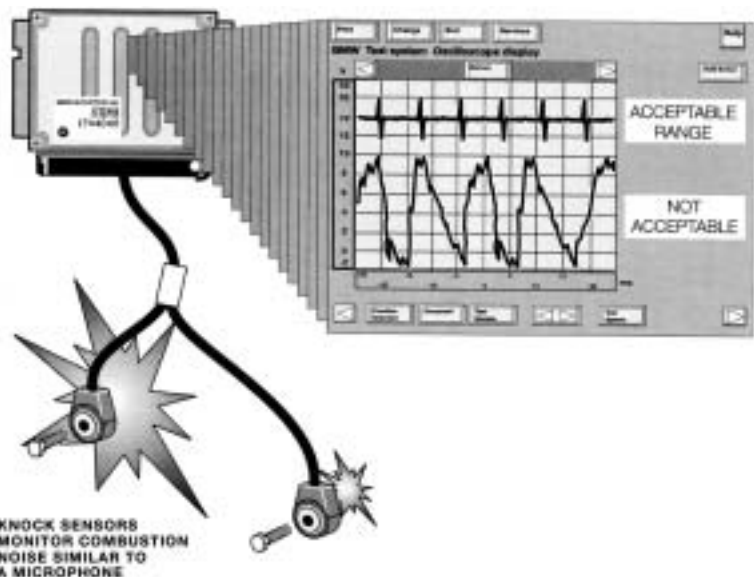

13550010

If a fault is detected with the Knock Sensor(s) or circuits, the ECM deactivates Knock Control. The ignition timing will be set to a conservative basic setting (to reduce the risk of detonation) and a fault will be stored. The “Malfunction Indicator Light” will be illuminated when the OBD II criteria is achieved.

Workshop Hints

Before any service work is performed on any ignition system related component, always adhere to the following:

- Observe relevant safety legislation pertaining to your area
- Always wear adequate protection clothing including eye protection
- Use caution when working around a HOT engine compartment
- Always consult the REPAIR INSTRUCTIONS on the specific model you are working on before attempting a repair.
- Always SWITCH OFF THE IGNITION (KL 15) before working on the ignition system.
- Use only BMW approved test leads.
- NEVER TOUCH COMPONENTS CONDUCTING CURRENT with the engine running.
- Do not connect suppression devices or a “test light” to terminal 1 of the ignition coils.
- Terminal 1 from the ignition coil to the ECM (High Voltage approximately 350 V)

HIGH VOLTAGE - DANGER!

Caution! Hazardous voltages occur at:

- Ignition Leads
- Spark Plug Connector
- Spark Plug
- Ignition Coil (High Voltage at terminal 4 is approximately 40 KV)
- Terminal 1 from the ignition coil to the ECM (High Voltage approximately 350V)

Ignition System Diagnosis

A fault survey should first be performed using the DISplus/GT1 to determine if there is a fault in the primary ignition or secondary ignition. If there is a fault in the primary ignition, testing should include:

- Power Supply at the coil (KL 15)
- Resistance of the harness and ignition coil primary winding
 - using the Universal Adapter with the ECM disconnected

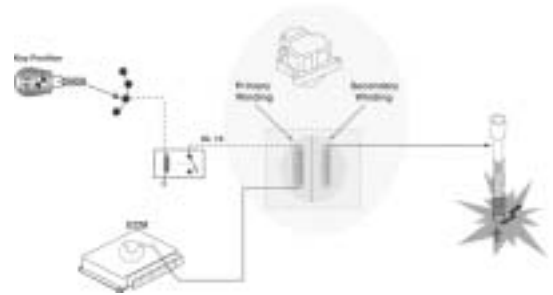

16550021

ECM Final Stage transistor activation. This test function is found under the Oscilloscope Preset list - "Ignition Signal Primary" (normal Terminal 1 Signal shown on the right).

Install the Universal Adapter, Diagnostic cable, MFK 2 negative lead to ECM ground and MFK 2 positive lead to the ground activation circuit for Terminal 1 of the ignition coil. This test is performed with the engine cranking/running.

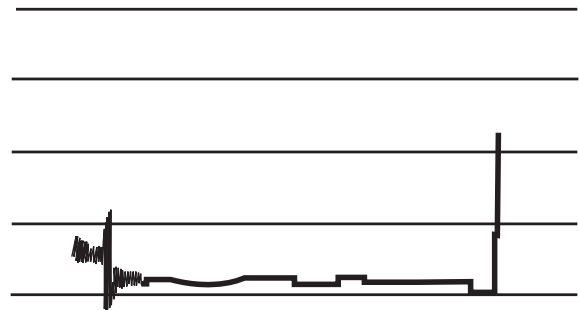

13550017

If there is a fault in the secondary ignition, testing should include:

- Primary Ignition
- Evaluation of Secondary Oscilloscope Patterns

The Following are Examples of Secondary Oscilloscope Patterns (consult Repair Instructions for ignition pattern variations per coil manufacturer):

This is a normal pattern for one ignition circuit with the engine at idle speed.

- Normal Combustion Period
- Normal Ignition Voltage Peak

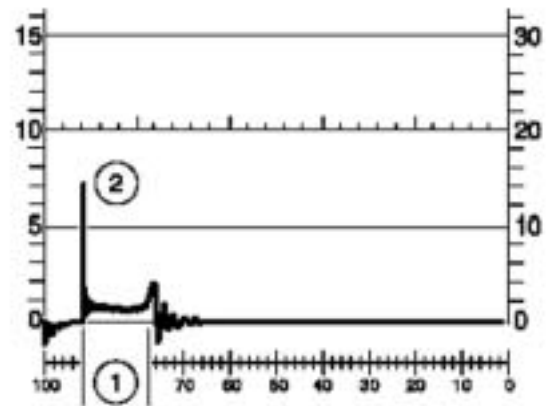

07550001

Multiple Ignition Pulses ensure good spark quality during engine start up. The ECM will activate the ignition coils 9 times per 720° of crankshaft revolution.

This is a normal pattern for one ignition circuit when:

1. Normal Combustion Period
2. Normal Ignition Voltage Peak

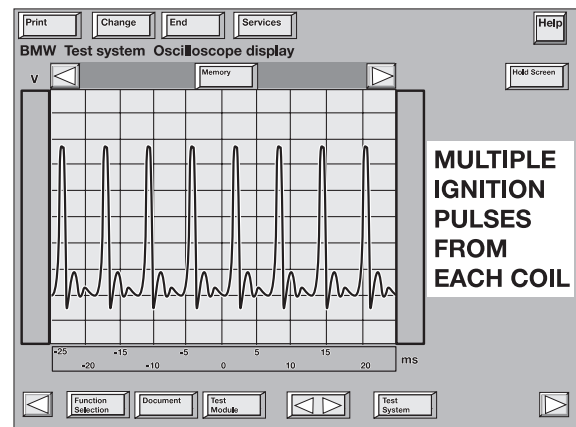

12550011

Long Spark Period (1) with Low Ignition Voltage Peak (2). If Spark Period is Fluctuating:

- Indicates Low Compression
- Contamination on Spark Plug or Defective Spark Plug

Short Spark Period (1) with High Ignition Voltage Peak (2).

- Defective Ignition Connector or Resistive Adaptive Boot

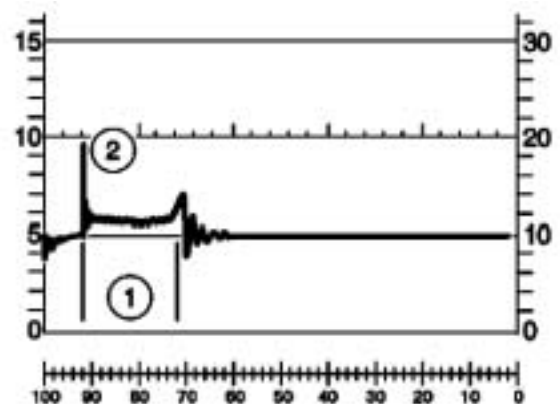

07550002

Evaluation of Ignition Voltage Peaks at Idle Speed (Multiple Cylinders Displayed).

1. Normal Attenuation (Voltage Reduction) Process
2. Shorten Attenuation Process (arrow)-Defective Ignition Coil
3. Absence of Attenuation (arrow)-Defective Ignition Coil

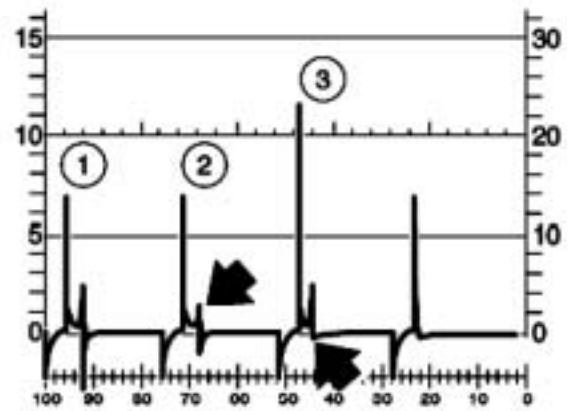

07550004

No Sparking Voltage Line (Single Cylinder Displayed)

- Defective Ignition Coil

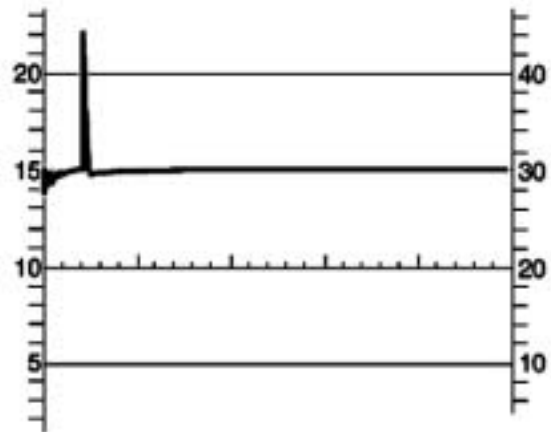

07550005

Evaluation of Ignition Voltage Peaks under Sudden Loads (Multiple Cylinders Displayed).

- Defective Ignition Coil

Decaying Process is considerably Higher than Ignition Voltage Peak (2):

- Lean Mixture
- Defective Fuel Injector
- Low Compression

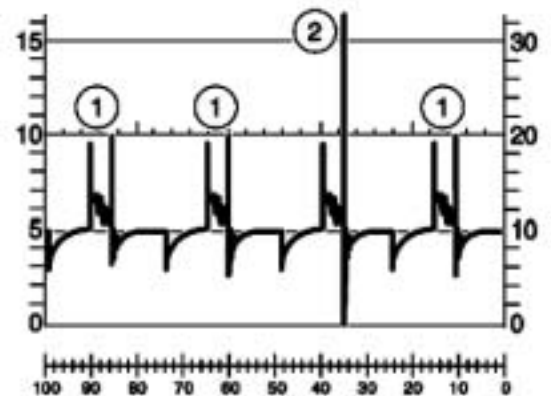

07550006

The Repair Instructions should be consulted for additional Oscilloscope Patterns under various engine speeds.

In Summary,

If the Secondary Ignition **Voltage is Too High (Excessive Resistance for Ignition):**

- Spark Plug Gap is too Large (Worn or Burned)
- Incorrect Heat Range Spark Plug
- Compression is too High (Carbon, etc.)
- Interruption in the Secondary Ignition Connector or Resistive Adapter Boot

If the Secondary Ignition **Voltage is Too Low (Low Resistance for Ignition):**

- Spark Plug Gap is Too Small (Mishandled on Installation)
- Incorrect Heat Range Spark Plug
- Compression is Too Low
- Voltage Leak in the Secondary Ignition Connector or Resistive Boot to Ground

Spark Plugs

The Spark Plugs should be inspected for the proper type, gap and replaced at the specified intervals.

Refer to the Service Information Bulletin S.I. #12 01 99 for the proper type and a visual of the spark plug (showing effects of combustion, fouling, etc.)

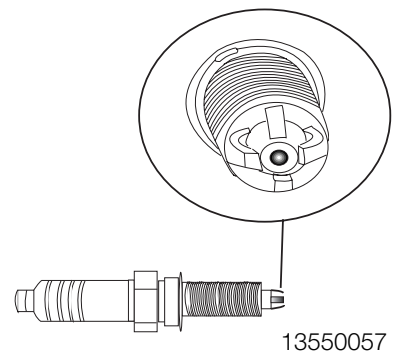

Knock Sensors

The Knock Sensors should be tested using the DIS/GT1 for:

- Fault Codes
- Status Display - Knock Control
(active / not active)
- Oscilloscope Display (Low DC Voltage -mV setting)

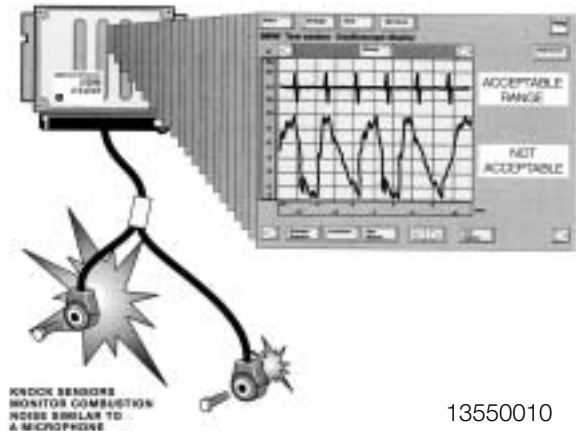

13550010

When installing Knock Sensors:

DO NOT MIX THE LOCATIONS or Engine Damage will result! The Knock Sensors use a combined connection to the engine harness. The Knock Sensor with the shorter cable is for cylinders 4 - 6.

Do Not Over Tighten attaching bolt! - Piezo ceramic will be cracked. Torque to 20 nm.

Do Not Under Tighten attaching bolt, a loose sensor can vibrate producing a similar signal to a knock.

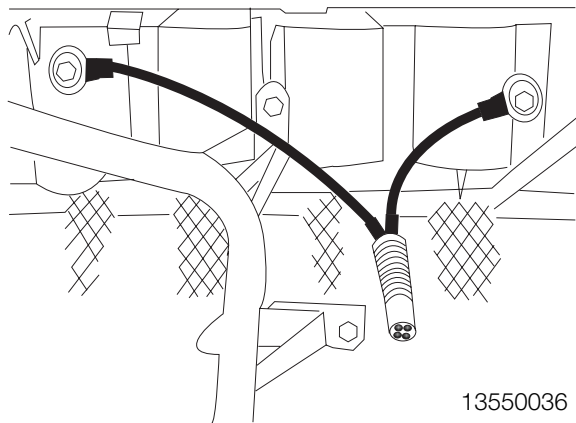

13550036

Tools and Equipment

The DISplus/GT1 as well as a reputable hand held multimeter can be used when testing inputs/components.

It is best to make the checks at the ECM connection, this method includes testing the wiring harness.

The correct Universal Adapter for the MS45 application should be used (#90 88 6 121 300). This will ensure the pin connectors and the harness will not be damaged.

When installing the Universal Adapter to the ECM, make sure the ignition is switched off.

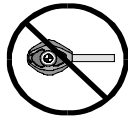

NOTE for MS45: Allow at least 3 minutes to elapse after the key was set to the "OFF" position before disconnecting the ECM/ TCM.

This will allow sufficient time to complete the DM TL test. Voltage may be present (up to 3 minutes) causing damage to the ECM/TCM if they are disconnected during this time period (arcing).

When Testing the Secondary Ignition System, use Special Tool (Secondary Voltage Test Cable) #90 88 6 127 050. This provides a clamping surface for the DISplus primary and secondary ignition adapter clamps. Refer to the HELP button for additional (on screen) connections.

Caution! Observe Safety Precautions, High Voltage is Present with the Engine Running

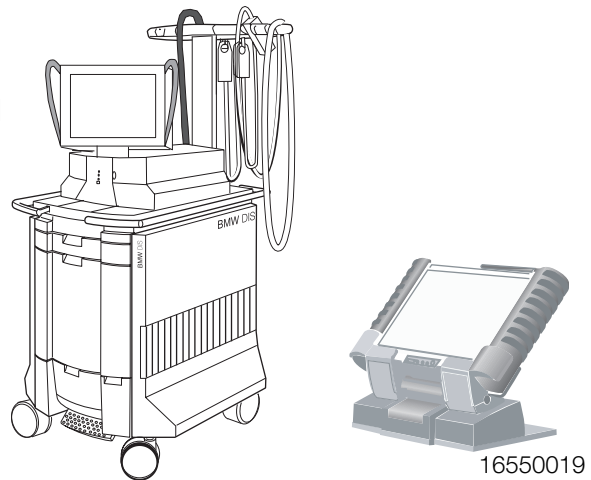

SKE BREAKOUT BOX SET
P/N 90 88 6 121 300

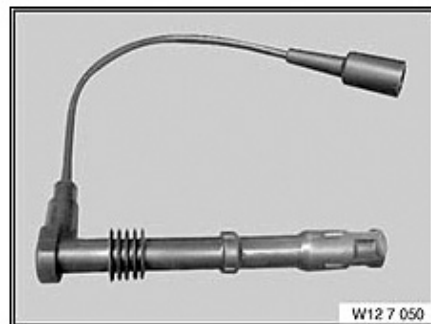
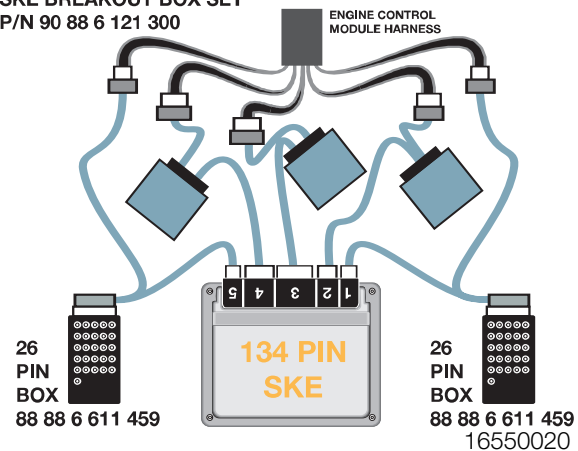

The Spark Plugs should be properly installed and torqued using the following Special Tools:

- 12 1 200 Torque Adapter
- 12 1 171 Spark Plug Socket

NOTE: NEVER USE AIR TOOLS FOR REMOVAL OR INSTALLATION!

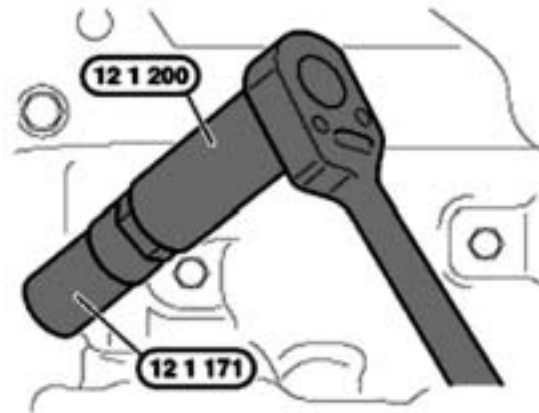

13550020

Emissions Management - M54B2.5 Low Emission Vehicle (LEV) - M54B3.0 Ultra Low Emission Vehicle (ULEV)

Evaporative Emissions: The control of the evaporative fuel vapors (Hydrocarbons) from the fuel tank is important for the overall reduction in vehicle emissions. The evaporative system has been combined with the ventilation of the fuel tank, which allows the tank to breath (equalization). The overall operation provides:

- An inlet vent, to an otherwise “sealed” fuel tank, for the the entry of air to replace the fuel consumed during engine operation.
- An outlet vent with a storage canister to “ trap and hold” fuel vapors that are produced by the expansion/evaporation of the fuel in the tank, when the vehicle is stationary.

The canister is then "purged" using the engine vacuum to draw the fuel vapors into the combustion chamber. This "cleans" the canister allowing for additional storage. Like any other form of combustible fuel, the introduction of these vapors on a running engine must be controlled.

The ECM controls the Evaporative Emission Valve which regulates purging of evaporative vapors. The evaporative system must be monitored for correct purge operation and Leak Detection.

1. Fuel supply line
2. Evaporative purge line
3. Evaporative vent line (to carbon canister)
4. Atmospheric vent line with filter
5. Carbon canister with DM TL pump

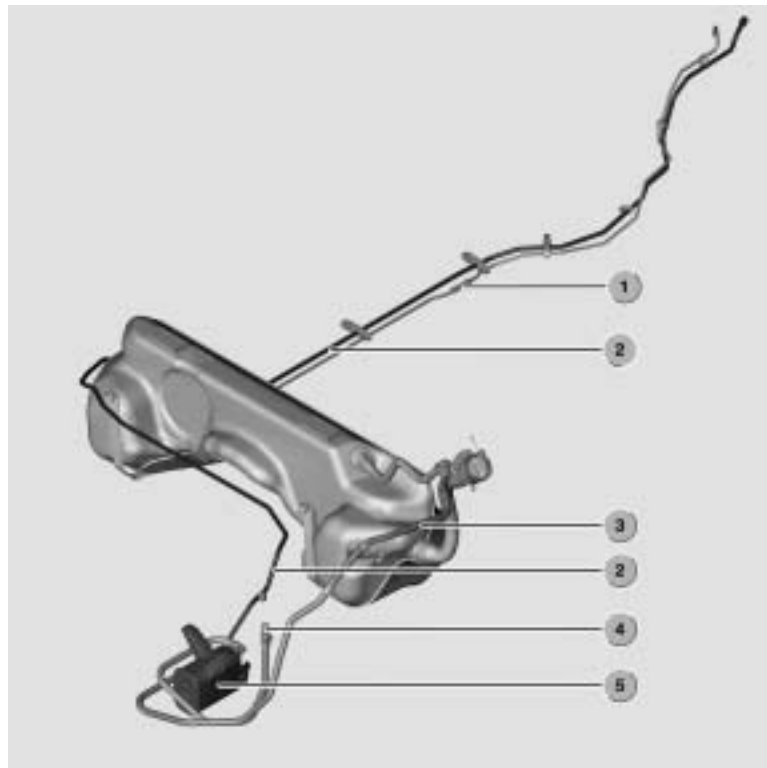

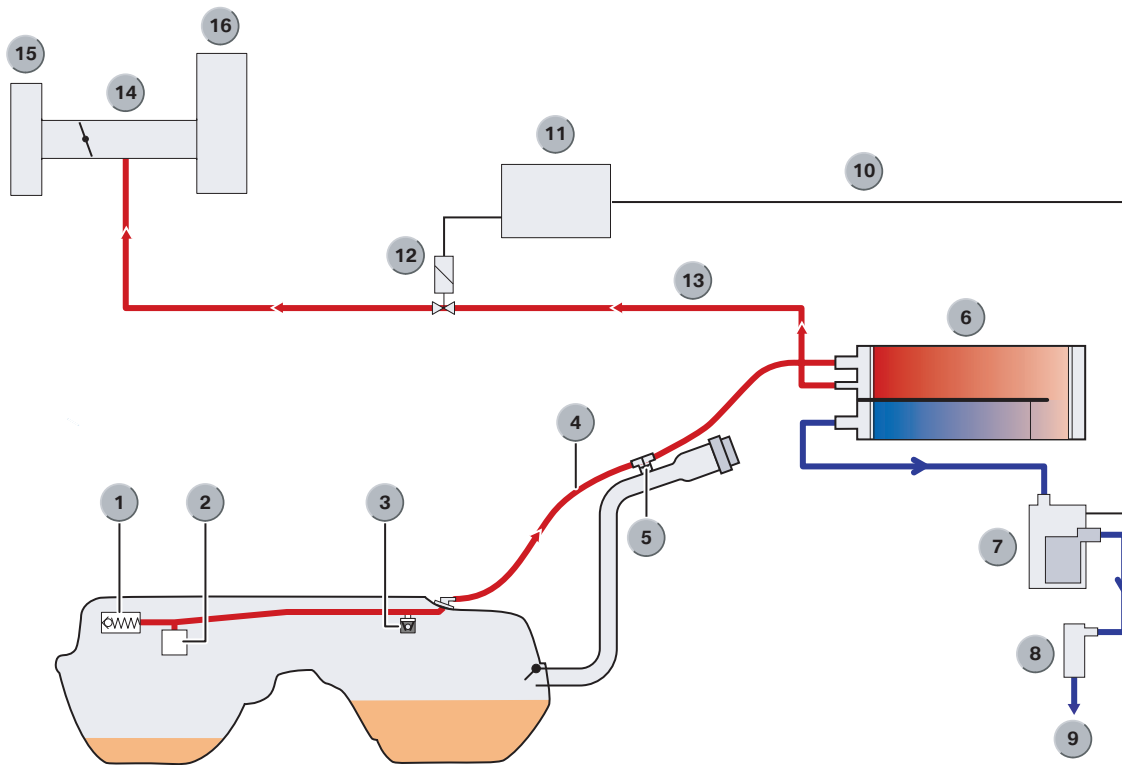

- | | |
|--|--|
| 1. Overpressure protection valve | 9. Atmospheric vent line |
| 2. Filling vent valve (rollover valve) | 10. DM TL (electrical control circuit) |
| 3. Operating vent valve | 11. ECM (DME) |
| 4. Ventilation line | 12. Evaporative emission (purge) control valve |
| 5. Mushroom valve ("T" fitting) | 13. Evaporative emission (purge) line |
| 6. Carbon canister | 14. Intake manifold |
| 7. DM TL (leakage diagnosis pump) | 15. Engine air filter |
| 8. Filter | 16. M54 engine |

On-Board Refueling Vapor Recovery (ORVR - DM TL Equipped Vehicles): The ORVR system recovers and stores hydrocarbon fuel vapor that was previously released during refueling. Non ORVR vehicles vent fuel vapors from the tank venting line back to the filler neck and in many states reclaimed by a vacuum receiver on the filling station's fuel pump nozzle.

When refueling an ORVR equipped vehicle, the pressure of the fuel entering the tank forces the hydrocarbon vapors through the Filling Vent Valve (2) and the large tank ventilation line (4) into the Carbon Canister (6). The HC is stored in the Carbon Canister and the system can then "breathe" through the DM TL (7) and the filter (8).

Note: A small diameter connection to the filler neck is provided by the Mushroom Valve "T fitting" (5). This is necessary for checking the filler cap/neck during Evaporative Leak Testing.

The ventilation continues until the rising fuel level lifts the float in the Filling Vent Valve (2) and closes the outlet. When the ventilation outlet is closed, a pressure cushion (vapor area) is created in the fuel tank. This creates a backup of fuel into the filler neck and the tank is full.

This leaves a vapor area of approximately 6 liters above the fuel level. This area provides integral liquid/vapor separation. The vapor condensates separate and drain back into the fuel. The remaining vapors exit the fuel tank (when sufficient pressure is present) through the Operating Vent Valve (3) to the Carbon Canister.

Note: The Operating Vent Valve is also equipped with a protection float in the event of an “overfill” situation.

Carbon Canister: As the hydrocarbon vapors enter the canister, they will be absorbed by the active carbon. The remaining air will be vented to the atmosphere through the end of the canister, DM TL and filter, allowing the fuel tank to “breathe”.

When the engine is running, the canister is "purged" using intake manifold vacuum to draw air through the canister which extracts the HC vapors into the combustion chamber.

The Carbon Canister with DM TL and air filter are located at the right rear underside of the vehicle, below the luggage compartment floor.



Evaporative Emission Valve: This ECM controlled solenoid valve regulates the purge flow from the Carbon Canister into the intake manifold. The ECM Relay provides operating voltage, and the ECM controls the valve by regulating the ground circuit. The valve is powered open and closed by an internal spring.

If the Evaporative Emission Valve circuit is defective, a fault code will be set and the “Malfunction Indicator Light” will illuminate when the OBD II criteria is achieved.

If the valve is “mechanically” defective, a drivability complaint could be encountered and a mixture related fault code will be set.

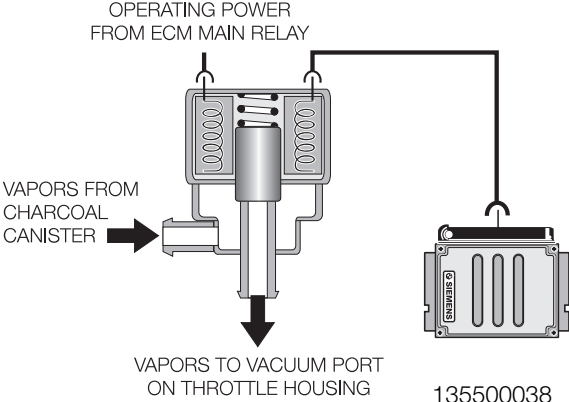

Evaporative Leakage Detection (DM TL): This component ensures accurate fuel system leak detection for leaks *as small as 0.5 mm* by slightly pressurizing the fuel tank and evaporative components. The DM TL pump contains an integral DC motor which is activated directly by the ECM. The ECM monitors the pump motor operating current as the measurement for detecting leaks.

The pump also contains an ECM controlled change over valve that is energized closed during a Leak Diagnosis test. The change over valve is open during all other periods of operation allowing the fuel system to “breathe” through the inlet filter. The DM TL is located under the luggage compartment floor with the Carbon Canister.

1. In its inactive state, filtered fresh air enters the evaporative system through the sprung open valve of the DM TL.
2. When the DME activates the DM TL for leak testing, it first activates only the pump motor. This pumps air through a restrictor orifice (0.5 mm) which causes the electric motor to draw a specific amperage value. This value is equivalent to the size of the restrictor.
3. The solenoid valve is then energized which seals the evaporative system and directs the pump output to pressurize the evaporative system.

- A large leak is detected in the evaporative system if the amperage value is not achieved.
- A small leak is detected if the same reference amperage is achieved.
- The system is sealed if the amperage value is higher than the reference amperage.

Since MY 2002, a heating element is integrated in the DM TL pump to eliminate condensation. The heater is provided battery voltage with “KL15” and the ECM provides the ground path.

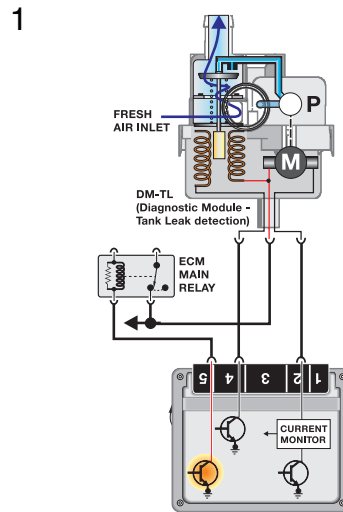

13410089

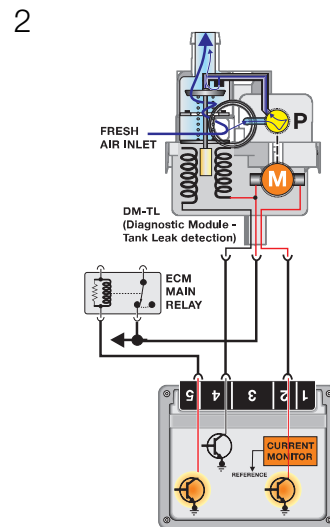

13410088

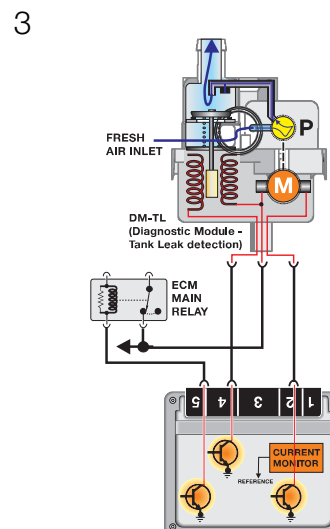

13410087

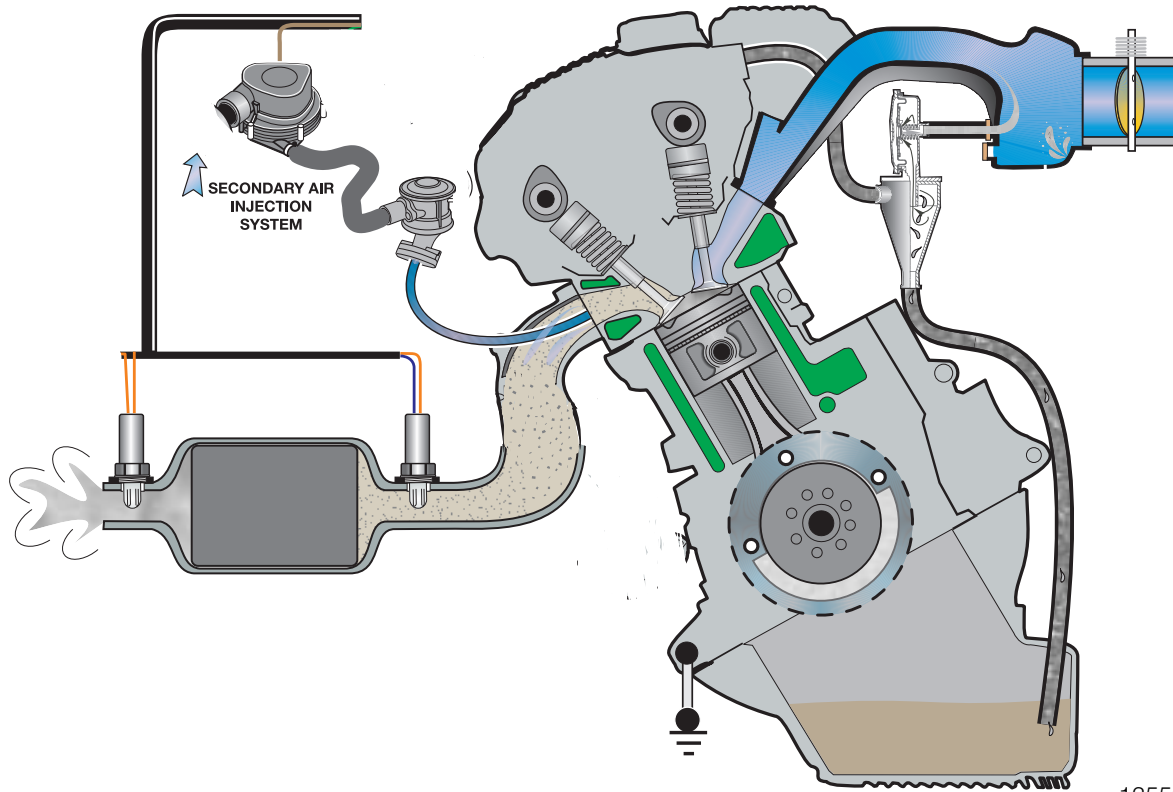

135500039

Exhaust Emissions: The combustion process of a gasoline powered engine produces Carbon Monoxide (CO), Hydrocarbons (HC) and Oxides of Nitrogen (NOx).

- Carbon Monoxide is a product of incomplete combustion under conditions of air deficiency. CO emissions are dependent on the air/fuel ratio.
- Hydrocarbon are also a product of incomplete combustion which results in unburned fuel. HC emissions are dependent on air/fuel ratio and the ignition of the mixture.
- Oxides of Nitrogen are a product of peak combustion temperature (and temperature duration). NOx emissions are dependent on internal cylinder temperature affected by the air/fuel ratio and ignition of the mixture.

Control of exhaust emissions is accomplished by the engine and engine management design as well as after-treatment.

- The ECM manages exhaust emissions by controlling the air/fuel ratio and ignition.
- The ECM controlled Secondary Air Injection further dilutes exhaust emissions leaving the engine and reduce the catalyst warm up time.
- The Catalytic Converter further reduces exhaust emissions leaving the engine.

Bosch LSH 25 Oxygen Sensors: The pre-cat oxygen sensors measure the residual oxygen content of the exhaust gas. The sensors produce a low voltage (0-1000 mV) proportional to the oxygen content that allows the ECM to monitor the air/fuel ratio.

The sensors are mounted in the hot exhaust stream directly in front of the catalytic converters.

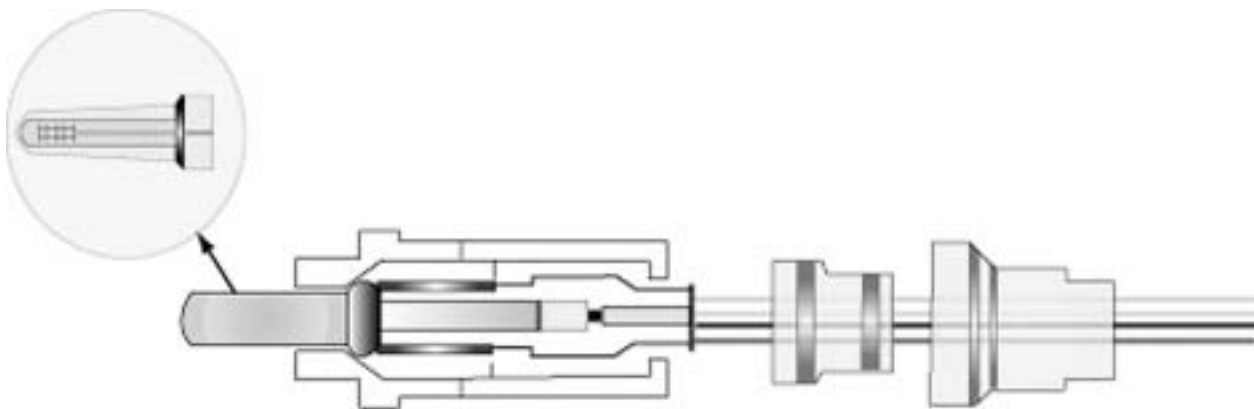
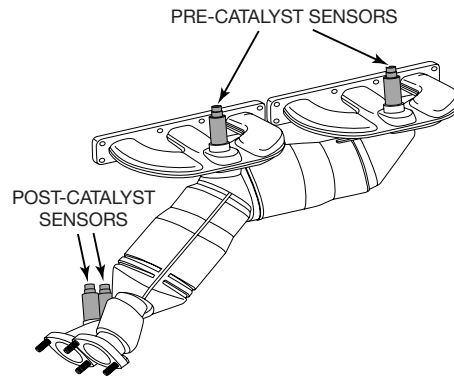

16550023

The “tip” of the sensor contains a microporous platinum coating (electrodes) which conduct current. The platinum electrodes are separated by solid electrolyte which conducts oxygen ions. The platinum conductors are covered with a highly porous ceramic coating and the entire tip is encased in a ventilated metal “cage”.

This assembly is submersed in the exhaust stream. The sensor body (external) has a small vent opening in the housing that allows ambient air to enter the inside of the tip.

The ambient air contains a constant level of oxygen content (21%) and the exhaust stream has a much lower oxygen content. The oxygen ions (which contain small electrical charges) are “purged” through the solid electrolyte by the hot exhaust gas flow. The electrical charges (low voltage) are conducted by the platinum electrodes to the sensor signal wire that is monitored by the ECM.

Notes: _____

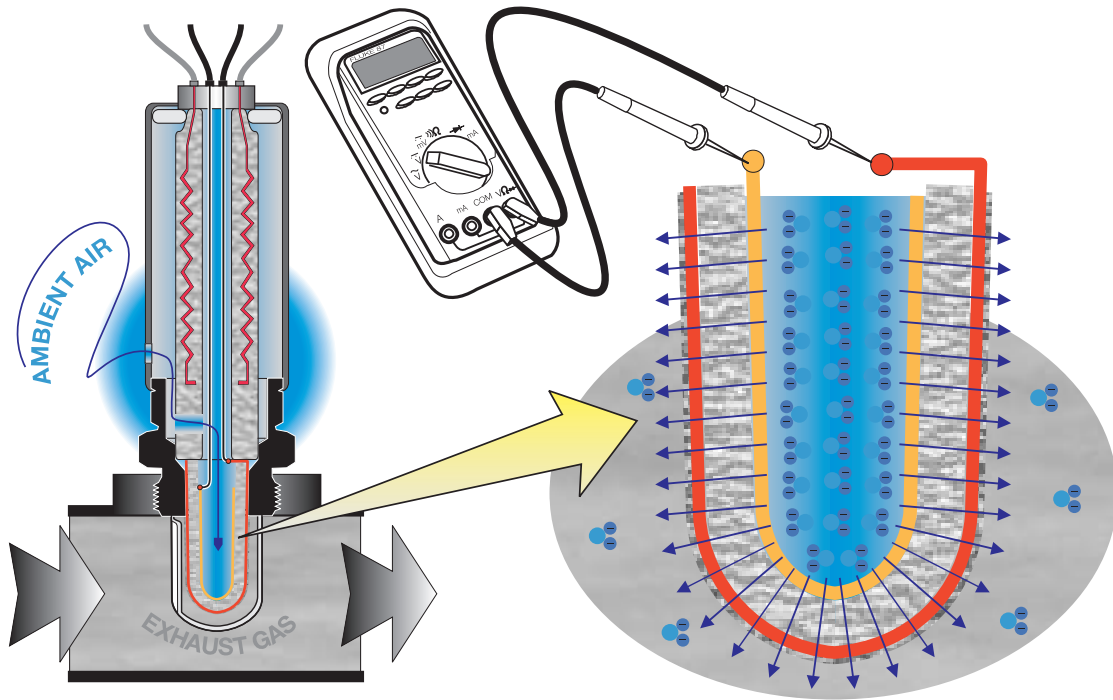

12410006

If the exhaust has a lower oxygen content (rich mixture), there will be a large ion “migration” through the sensor generating a higher voltage (950 mV).

If the exhaust has a higher oxygen content (lean mixture), there will be a small ion “migration” through the sensor generating a lower voltage (080 mV).

This voltage signal is constantly changing due to combustion variations and normal exhaust pulsations.

The ECM monitors the length of time the sensors are operating in the lean, rich (including the time of rise and fall) and rest conditions. The evaluation period of the sensors is over a pre-defined number of oscillation cycles.

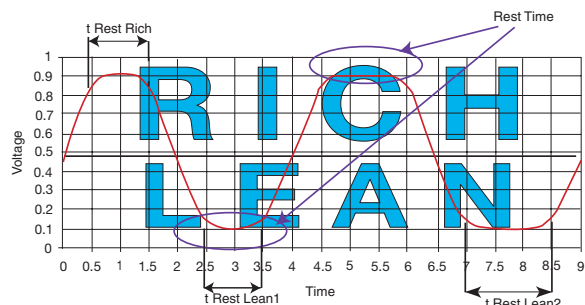

13550011

This conductivity is efficient when the oxygen sensor is hot (250° - 300° C). For this reason, the sensor contains a heating element. This “heated” sensor reduces warm up time, and retains the heat during low engine speed when the exhaust temperature is cooler.

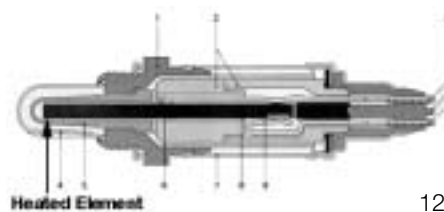

12410006

Direct Oxygen Sensor Heating: The oxygen sensor conductivity is efficient when it is hot (600° - 700° C). For this reason, the sensors contain heating elements. These “heated” sensors reduce warm up time, and retain the heat during low engine speed when the exhaust temperature is cooler. OBD II requires monitoring of the oxygen sensor heating function and heating elements for operation.

The four oxygen sensor heating circuits receive operating voltage from the ECM Relay when KL15 is switched “ON”. Each of the sensors heaters are controlled through separate final stage transistors.

The sensor heaters are controlled with a pulse width modulated voltage during a cold start. This allows the sensors to be brought up to operating temperature without the possibility of thermal shock. The duty cycle is then varied to maintain the heating of the sensors.

When the engine is decelerating (closed throttle), the ECM increases the duty cycle of the heating elements to compensate for the decreased exhaust temperature.

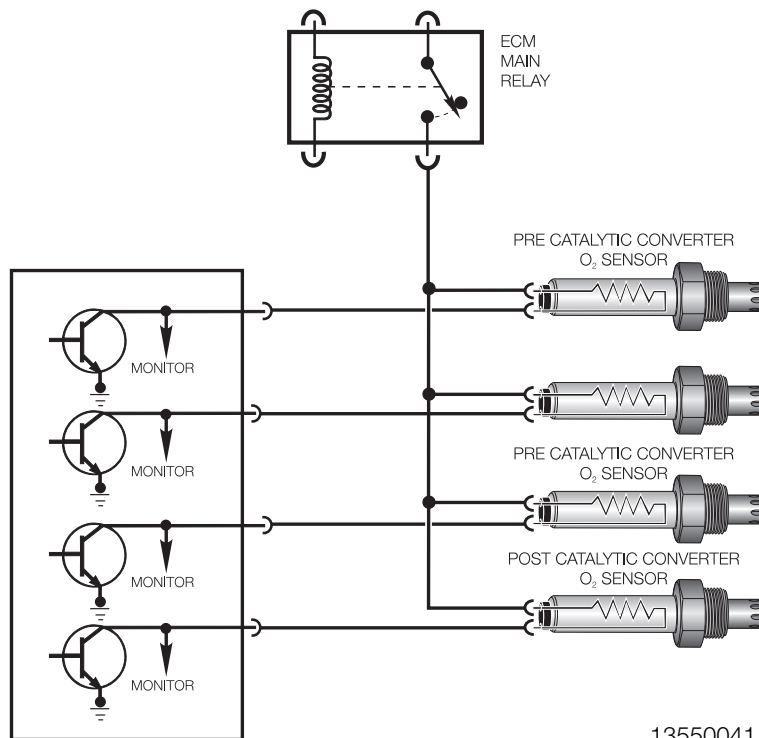

Catalytic Converter Monitoring: The efficiency of catalyst operation is determined by evaluating the oxygen consumption of the catalytic converters using the pre and post oxygen sensor signals. A properly operating catalyst consumes most of the O₂ (oxygen) that is present in the exhaust gas (input to catalyst). The gases that flow into the catalyst are converted from CO, HC and NO_x to CO₂, H₂O and N₂ respectively.

In order to determine if the catalysts are working correctly, post catalyst oxygen sensors are installed to monitor exhaust gas content exiting the catalysts. The signal of the post cat. O₂ sensor is evaluated over the course of several pre cat. O₂ sensor oscillations.

During the evaluation period, the signal of the post cat. sensor must remain within a relatively constant voltage range (700 - 800 mV). The post cat. O₂ voltage remains high with a very slight fluctuation. This indicates a further lack of oxygen when compared to the pre cat. sensor.

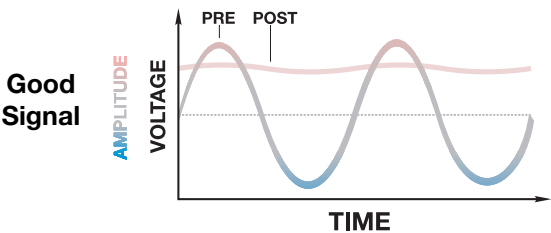

If this signal decreased in voltage and/or increased in fluctuation, a fault code will be set for Catalyst Efficiency and the “Malfunction Indicator Light” will illuminate when the OBD II criteria is achieved.

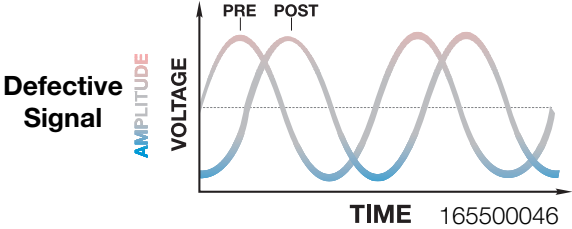

Secondary Air Injection: Injecting ambient air into the exhaust stream after a cold engine start reduces the warm up time of the catalyst and reduces HC and CO emissions. The ECM controls and monitors the Secondary Air Injection.

An Electric Secondary Air Pump and Air Injection Valve direct fresh air through an internal channel in the cylinder head into the exhaust ports. The Air Injection Valve is opened by air pressure (from the pump) and is closed by an internal spring.

The E85 uses a higher volume Secondary Air Pump (45 kg/hour). The pump contains an integral air filter element which is maintenance free.

- 1. Air filter
- 2. Secondary air pump (SLP)
- 3. Air injection valve (SLV)



Misfire Detection: As part of the OBD II regulations the ECM must determine misfire and also identify the specific cylinder(s), the severity of the misfire and whether it is emissions relevant or catalyst damaging based on monitoring crankshaft acceleration.

In order to accomplish these tasks the ECM monitors the crankshaft for acceleration by the impulse wheel segments of cylinder specific firing order. The misfire/engine roughness calculation is derived from the differences in the period duration of individual increment gear segments.

Each segment period consist of an angular range of 90° crank angle that starts 54° before Top Dead Center.

If the expected period duration is greater than the permissible value a misfire fault for the particular cylinder is stored in the fault memory of the ECM.

Depending on the level of misfire rate measured the ECM will illuminate the "Malfunction Indicator Light", deactivate the specific fuel injector to the particular cylinder and switch oxygen sensor control to open-loop.

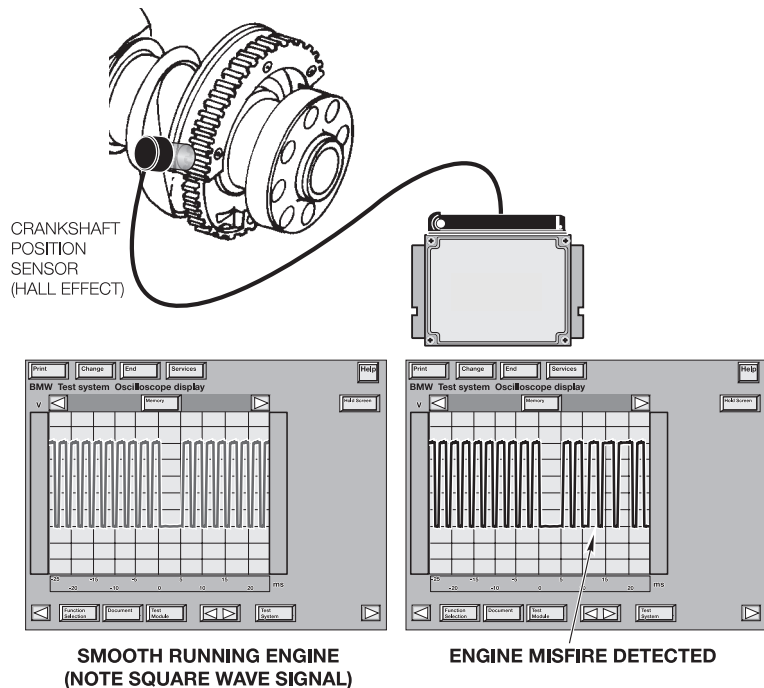

134100101

In order to eliminate misfire faults that can occur as a result of varying flywheel tolerances (manufacturing process) an internal adaptation of the flywheel is made. The adaptation is made during periods of decel fuel cut-off in order to avoid any rotational irregularities which the engine can cause during combustion. This adaptation is used to correct segment duration periods prior to evaluation for a misfire event.

If the sensor wheel adaptation has not been completed the misfire thresholds are limited to engine speed dependent values only and misfire detection is less sensitive. The crankshaft sensor adaptation is stored internally and is not displayed via DISplus or GT1. If the adaptation limit is exceeded a fault will be set.

Principle of Operation

Emissions Management controls evaporative and exhaust emissions. The ECM monitors the fuel storage system for **evaporative leakage** and controls the **purging** of evaporative vapors. The ECM monitors and controls the exhaust emissions by regulating the **combustible mixture** and after treating by injecting **fresh air** into the exhaust system. The catalytic converter further breaks down remaining combustible exhaust gases and is monitored by the ECM for **catalyst efficiency**.

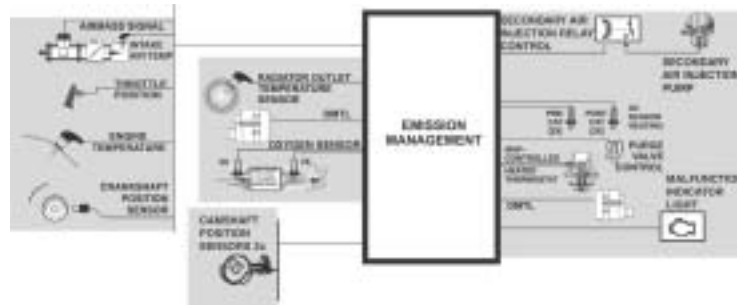

45-02-07

The MS45 Evaporative Leakage Detection is performed on the fuel storage system by the DM TL pump which contains an integral DC motor that is activated by the ECM. The ECM monitors the pump motor operating current as the measurement for detecting leaks. The pump also contains an ECM controlled change over valve that is energized closed during a Leak Diagnosis test. The ECM initiates a leak diagnosis test every time the criteria are met. The criteria is as follows:

- Engine **OFF** with ignition switched **OFF**.
- ECM still in active state or what is known as “follow up mode” (ECM Relay energized, ECM and components online for extended period after key off).
- Prior to Engine/Ignition switch OFF condition, vehicle must have been driven for a minimum of 20 minutes.
- Prior to minimum 20 minute drive, the vehicle must have been OFF for a minimum of 5 hours.
- Fuel Tank Capacity must be between **15 and 85%** (safe approximation between 1/4 - 3/4 of a tank).
- Ambient Air Temperature between **4°C & 35°C** (40°F & 95°F)
- Altitude < **2500m** (8,202 feet).
- Battery Voltage - **between 10.95 and 14.5 Volts**

PHASE 1 - Reference Measurement

The ECM activates the pump motor. The pump pulls air from the filtered air inlet and passes it through a precise 0.5 mm reference orifice in the pump assembly. The ECM simultaneously monitors the pump motor current flow. The motor current raises quickly and levels off (stabilizes) due to the orifice restriction. The ECM stores the stabilized amperage value in memory. The stored amperage value is the electrical equivalent of a 0.5 mm (0.020”) leak.

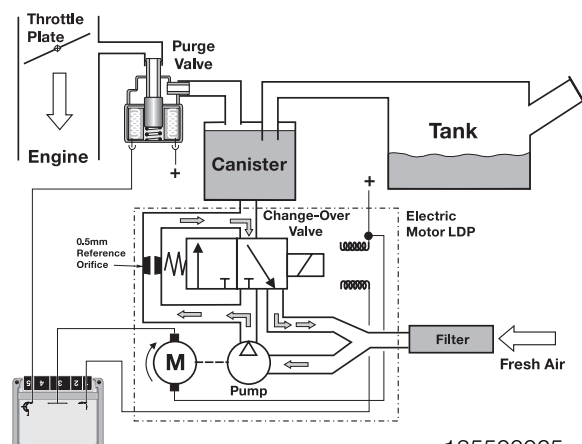

135500065

PHASE 2 - Leak Detection

The ECM energizes the Change Over Valve allowing the pressurized air to enter the fuel system through the Charcoal Canister. The ECM monitors the current flow and compares it with the stored reference measurement over a duration of time.

Once the test is concluded, the ECM stops the pump motor and immediately de-energizes the change over valve. This allows the stored pressure to vent through the charcoal canister trapping hydrocarbon vapor and venting air to atmosphere through the filter.

Test Results

The time duration varies between 45 & 270 seconds depending on the resulting leak diagnosis test results (developed tank pressure “amperage”/within a specific time period). However the chart depicts the logic used to determine fuel system leaks.

If the ECM detects a leak, a fault will be stored and the “Malfunction Indicator Light” will be illuminated. Depending on the amperage measurement detected by the ECM, the fault code displayed will be *small leak* or *large leak*.

Refuelling during the test will interrupt the diagnosis and the DM TL will be denergized. The ECM detects this by:

- Pressure drop when filler cap is removed
- Rise in pressure due to refuelling

If refuelling does not take place immediately after opening the filler cap (pressure rise missing), a *large leak* is detected.

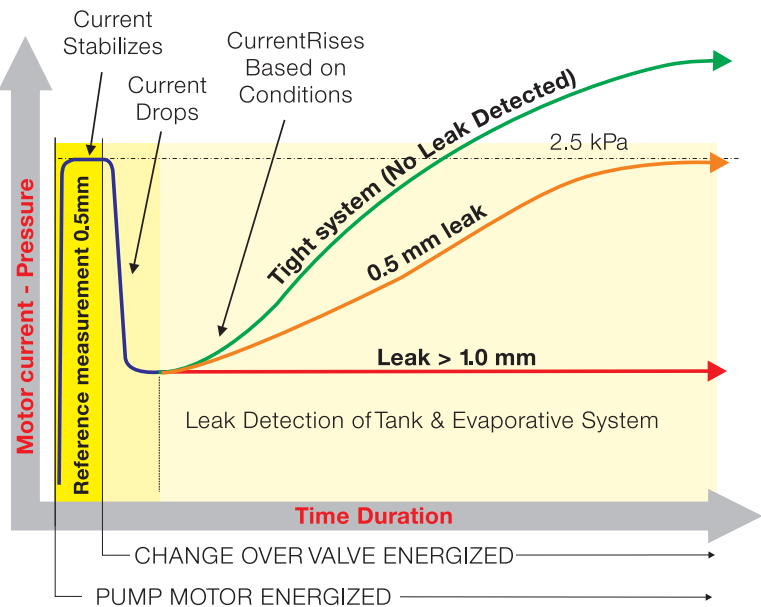
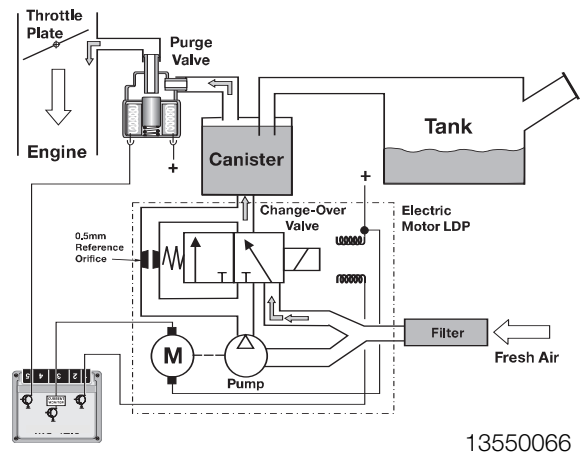
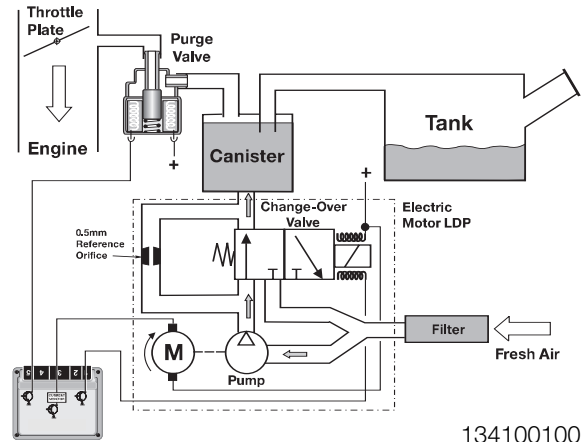

13550064

If the vehicle was refueled and the filler cap was not properly installed, the “*Check Filler Cap*” message will be displayed in the instrument cluster for 20 seconds.

CHECK
FILLER
CAP

If the filler cap is installed and there is no leakage present the next time the leakage test is performed, the “Malfunction Indicator Light” will not be illuminated (additional detailed information on page 82 of Workshop Hints).

Evaporative Emission Purging is regulated by the ECM controlling the Evaporative Emission Valve. The Evaporative Emission Valve is a solenoid that regulates purge flow from the Active Carbon Canister into the intake manifold. The ECM Relay provides operating voltage, and the ECM controls the valve by regulating the ground circuit. The valve is powered open and closed by an internal spring.

The “purging” process takes place when:

- Oxygen Sensor Control is active
- Engine Coolant Temperature is $>67^{\circ}\text{C}$
- Engine Load is present

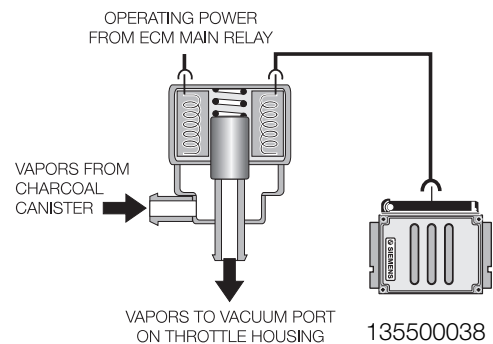

The Evaporative Emission Valve is opened in stages to moderate the purging.

- Stage 1 opens the valve for 10 ms (milli-seconds) and then closes for 150 ms.
- The stages continue with increasing opening times (up to 16 stages) until the valve is completely open.
- The valve now starts to close in 16 stages in reverse order
- This staged process takes 6 minutes to complete. The function is inactive for 1 minute then starts the process all over again.
- During the purging process the valve is completely opened during full throttle operation and is completely closed during deceleration fuel cutoff.

Evaporative Purge System Flow Check is performed by the ECM when the oxygen sensor control and purging is active. When the Evaporative Emission Valve is open the ECM detects a rich/lean shift as monitored by the oxygen sensors indicating the valve is functioning properly.

If the ECM does not detect a rich/lean shift, a second step is performed when the vehicle is stationary and the engine is at idle speed. The ECM opens and close the valve (abruptly) several times and monitors the engine rpm for changes. If there are no changes, a fault code will be set.

Fuel System Monitoring is performed by the ECM which verifies the calculated injection time (t_i) in relation to engine speed, load and the oxygen sensor signal as a result of the residual oxygen in the exhaust stream.

The ECM uses the oxygen sensor signal as a correction factor for adjusting and optimizing the mixture pilot control under all engine operating conditions.

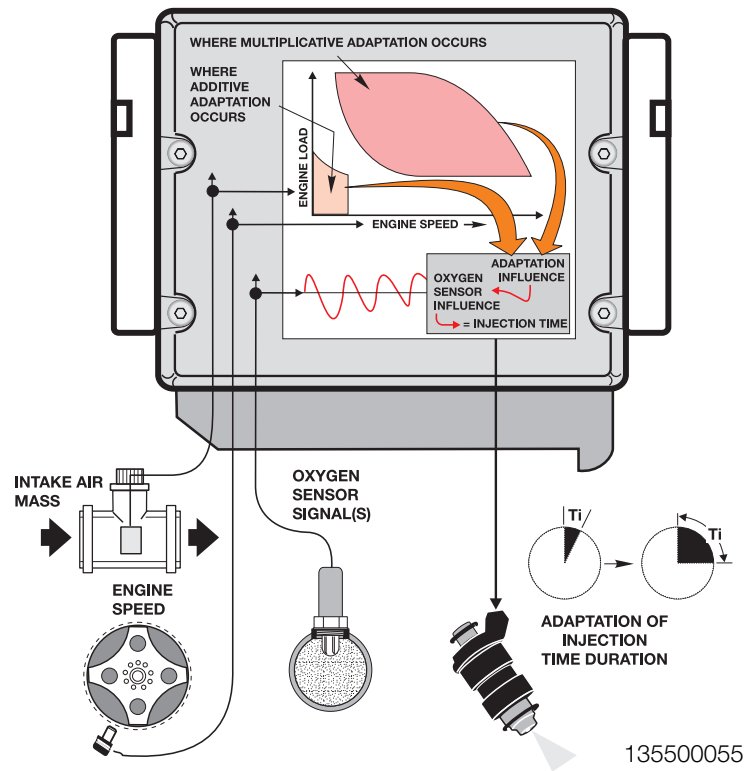

Adaptation Values are stored by the ECM in order to maintain an "ideal" air/fuel ratio. The ECM is capable of adapting to various environmental conditions encountered while the vehicle is in operation (changes in altitude, humidity, ambient temperature, fuel quality, etc.).

The adaptation can only make slight corrections and can not compensate for large changes which may be encountered as a result of incorrect airflow or incorrect fuel supply to the engine.

Within the areas of adjustable adaptation, the ECM modifies the injection rate under two areas of engine operation:

- During idle and low load mid range engine speeds (Additive Adaptation).
- During operation under a normal to higher load when at higher engine speeds (Multiplicative Adaptation).

These values indicate how the ECM is compensating for a less than ideal initial air/fuel ratio.

NOTE: If the adaptation value is greater than "0.0" Additive (% Multiplicative), the ECM is trying to richen the mixture. If the adaptation value is less than "0.0" Additive (% Multiplicative), the ECM is trying to lean-out the mixture.

Catalyst Monitoring is performed by the ECM under oxygen sensor closed loop operation. The changing air/fuel ratio in the exhaust gas results in lambda oscillations at the pre-catalyst sensors. These oscillations are dampened by the oxygen storage activity of the catalysts and are reflected at the post catalyst sensors as a fairly stable signal (indicating oxygen has been consumed). Conditions for Catalyst Monitoring:

Requirements

- Closed loop operation
- Engine coolant temperature
- Vehicle road speed
- Catalyst temperature (calculated)
- Throttle angle deviation
- Engine speed deviation
- Average lambda value deviation

Status/Condition

- YES
- Operating Temp. 3 - 50 MPH (5 to 80 km/h)
- 350°C to 650°C
- Steady throttle
- Steady/stable engine speed
- Steady/stable load

* Catalyst temperature is an internally calculated value that is a function of load/air mass and time.

As part of the monitoring process, the pre and post O₂ sensor signals are evaluated by the ECM to determine the length of time each sensor is operating in the rich and lean range.

If the catalyst is defective the post O₂ sensor signal will reflect the pre O₂ sensor signal (minus a phase shift/time delay), since the catalyst is no longer able to store oxygen.

The catalyst monitoring process is stopped once the predetermined number of cycles are completed, until the engine is shut-off and started again. After completing the next "customer driving cycle" whereby the specific conditions are met and a fault is again set, the "Malfunction Indicator Light" will be illuminated.

Note: The catalyst efficiency is monitored once per trip while the vehicle is in closed loop operation.

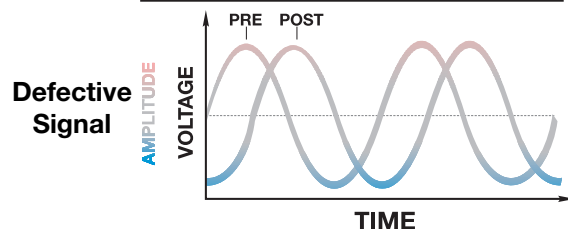
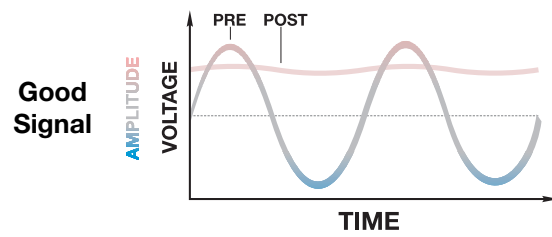
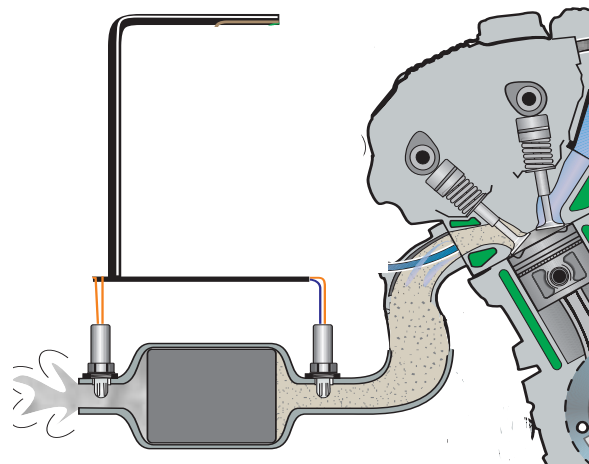

Secondary Air Injection is required to reduce HC and CO emissions while the engine is warming up. Immediately following a cold engine start (-10 to 60°C) fresh air/oxygen is injected directly into the exhaust stream.

The temperature signal is provided to the ECM by the Air Temperature Sensor in the HFM*.

The ECM provides a ground circuit to activate the Secondary Air Injection Pump Relay. The relay supplies voltage to the Secondary Air Injection Pump.

The single speed pump runs for approximately 90 seconds after engine start up.

* Below -10° C the pump is activated briefly to “blow out” any accumulated moisture.

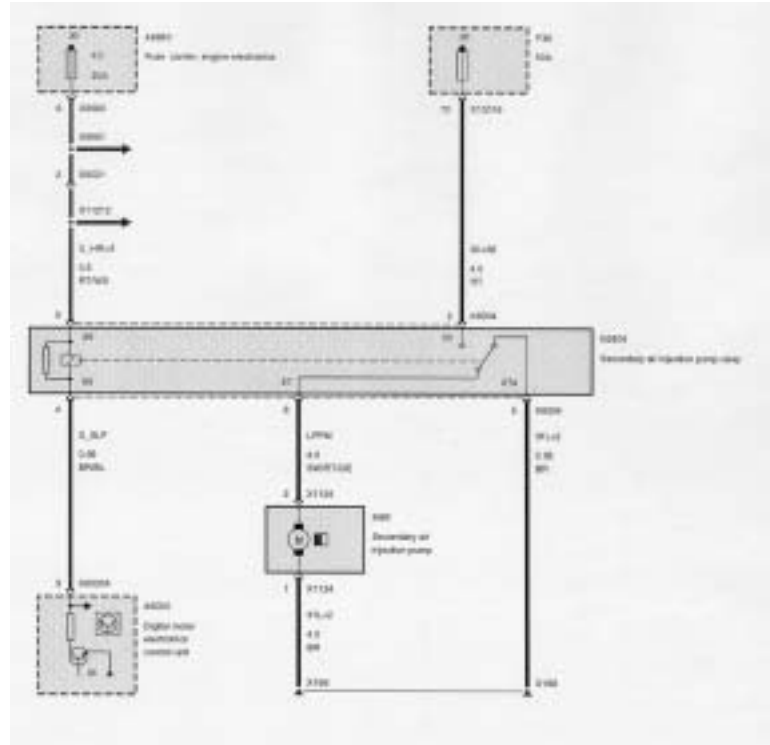

Secondary Air Injection Monitoring is performed by the ECM via the use of the pre-catalyst oxygen sensors. Once the air pump is active and is air injected into the exhaust system the oxygen sensor signals will indicate a lean condition (up to 16 seconds).

If the oxygen sensor signals do not change within a predefined time a fault will be set and identify the faulty bank.

If the additional oxygen is not detected for two consecutive cold starts, the ECM determines a general fault with the function of the secondary air injection system. After completing the next cold start and a fault is again present the "Malfunction Indicator Light" will be illuminated when the OBD II criteria is achieved.

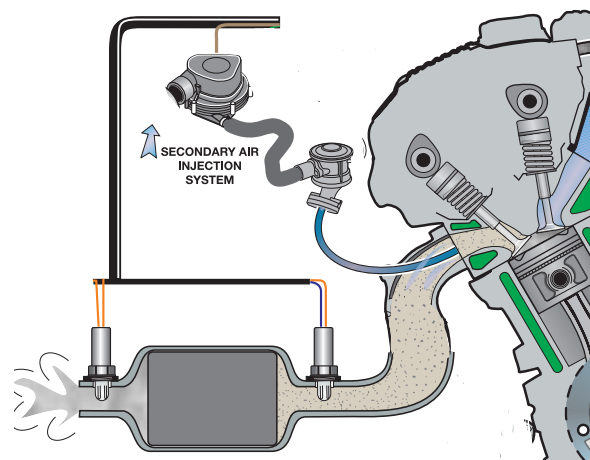

Misfire Detection is part of the OBD II regulations the ECM must determine misfire and also identify the specific cylinder(s). The ECM must also determine the severity of the misfire and whether it is emissions relevant or catalyst damaging based on monitoring crankshaft acceleration.

Emission Increase:

- Within an interval of 1000 crankshaft revolutions, the ECM adds the the detected misfire events for each cylinder. If the sum of all cylinder misfire incidents exceeds the predetermined value, a fault code will be stored and the “Malfunction Indicator Light” will be illuminated.
- If more than one cylinder is misfiring, all misfiring cylinders will be specified and the individual fault codes for each misfiring cylinder, or multiple cylinders will be stored. The “Malfunction Indicator Light” will be illuminated.

Catalyst Damage:

- Within an interval of 200 crankshaft revolutions the detected number of misfiring events is calculated for each cylinder. The ECM monitors this based on load/rpm. If the sum of cylinder misfire incidents exceeds a predetermined value, a “Catalyst Damaging” fault code is stored and the “Malfunction Indicator Light” will be illuminated.

If the cylinder misfire count exceeds the predetermined threshold the ECM will take the following measures:

- The oxygen sensor control will be switched to open loop.
- The cylinder selective fault code is stored.
- If more than one cylinder is misfiring the fault code for all individual cylinders and for multiple cylinders will be stored.
- The fuel injector to the respective cylinder(s) is deactivated.

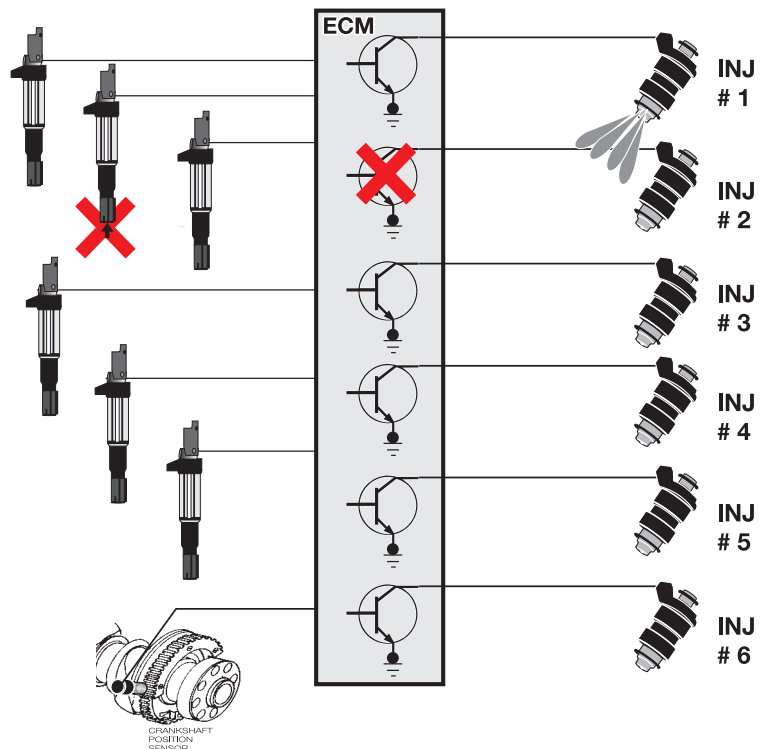

Electrically Heated Thermostat

Model specific variants of the electrically heated thermostat are equipped on all LEV/ULEV compliant engines. This thermostat allows the engine to run more efficiently than conventional thermostats improving fuel economy.

The ECM also electrically activates the thermostat to lower the engine coolant temperatures based on monitored conditions. It is both a conventionally functioning and ECM controlled thermostat (two stage operation). ECM control adds heat to the wax core causing the thermostat to open earlier than its mechanical temperature rating providing increased coolant flow.

Conventional Function: The thermostat begins to open at 103°C. This is at the inlet side of the water pump and represents the temperature of the coolant entering the engine. Before the 103°C temperature is realized, the coolant is circulated through the engine block by the water pump.

After the temperature reaches 103°C it is maintained as the inlet temperature by the thermostat. The coolant temperature at the water pump engine outlet is approximately 110°C. The additional 7°C is achieved after the coolant has circulated through the block.

The operating temperature of the engine will remain within this range as long as the engine is running at part load conditions and the engine coolant temperature does not exceed 113°C.

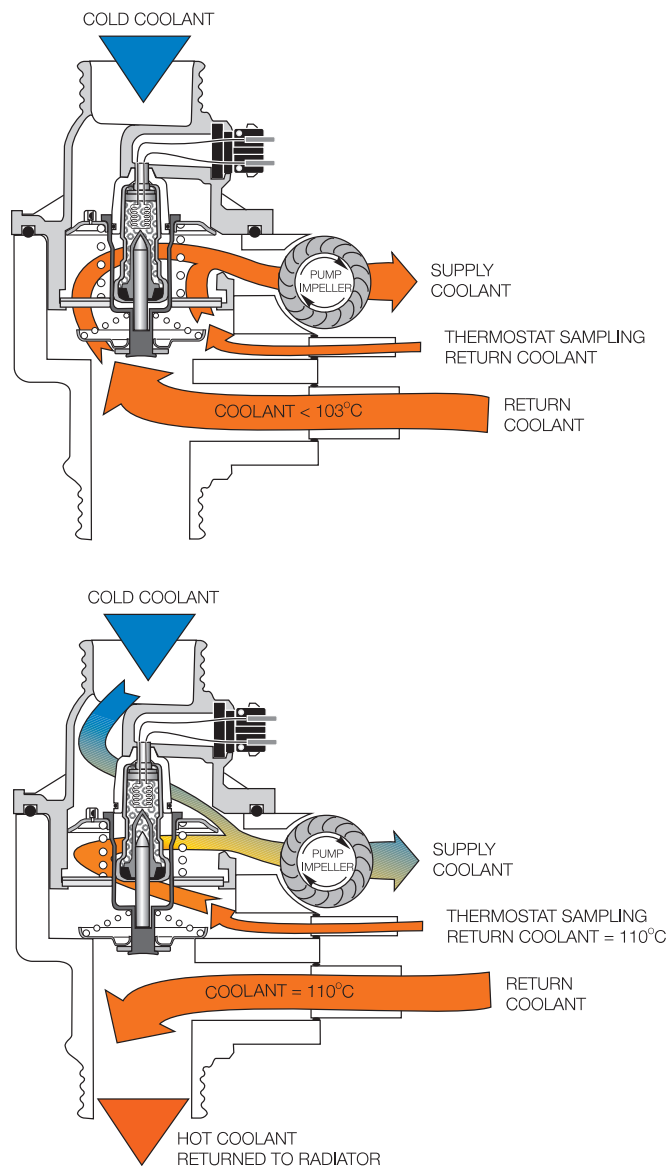
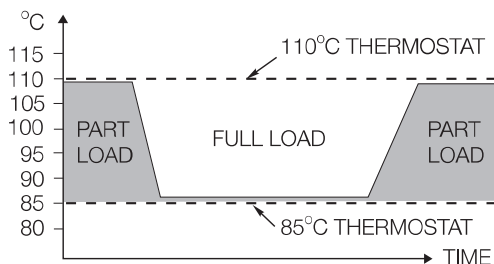

ECM Control

Electric thermostat activation is based on the following parameters:

- Engine temperature > 113°C
- Radiator Coolant Outlet Temperature
- Load signal "ti" > 5.8 ms
- Intake air temp > 52°C
- Vehicle speed > 110 MPH

When one or more of these monitored conditions is determined, the ECM activates (switched ground) the thermostat circuit. The activated heating element causes the wax core in the thermostat to heat up and open the thermostat increasing coolant circulation through the radiator which brings the engine temperature down.

The temperature of the coolant at the inlet side of the water pump will drop to approximately 85°C and the temperature at the outlet side will drop to approximately 103°C when activated.

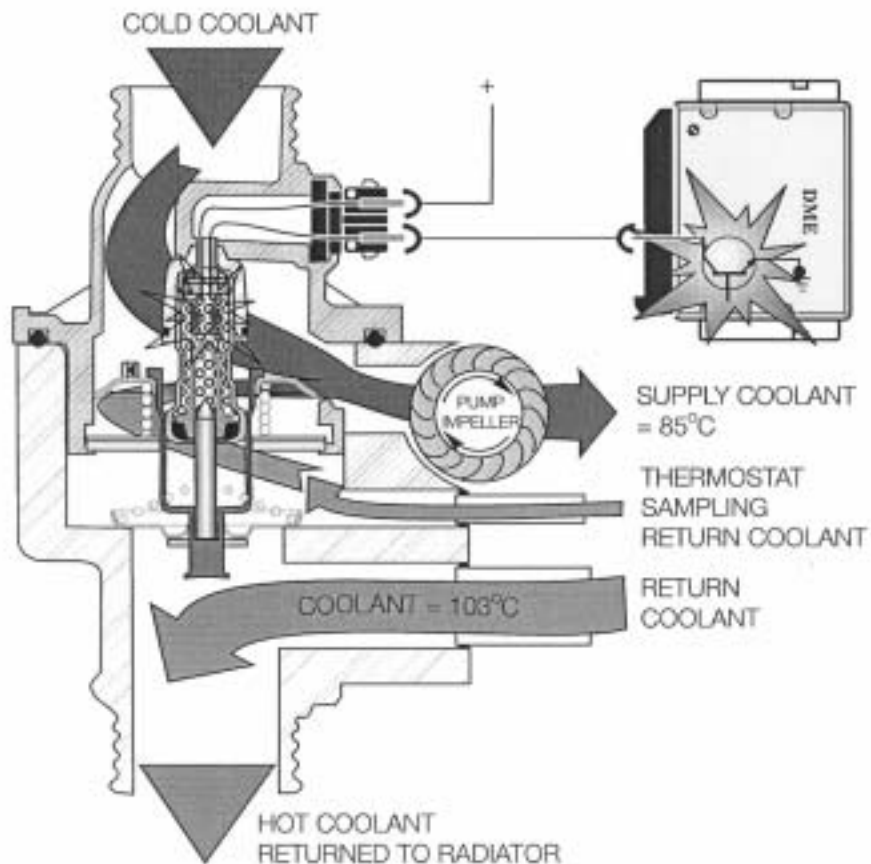

The “**Malfunction Indicator Light**” (MIL) will be illuminated under the following conditions:

- Upon the completion of the **next consecutive driving cycle** where the previously faulted system is monitored again and the emissions relevant fault is again present.
- Immediately if a “Catalyst Damaging” fault occurs (see Misfire Detection).

The illumination of the light is performed in accordance with the Federal Test Procedure (FTP) which requires the lamp to be illuminated when:



- A malfunction of a component that can affect the emission performance of the vehicle occurs and causes emissions to exceed 1.5 times the standards required by the (FTP).
- Manufacturer-defined specifications are exceeded.
- An implausible input signal is generated.
- Catalyst deterioration causes HC-emissions to exceed a limit equivalent to 1.5 times the standard (FTP).
- Misfire faults occur.
- A leak is detected in the evaporative system, or “purging” is defective.
- ECM fails to enter closed-loop oxygen sensor control operation within a specified time interval.
- Engine control or automatic transmission control enters a "limp home" operating mode.
- Ignition is on (KL15) position before cranking = **Bulb Check Function**.

Within the BMW system the illumination of the Malfunction Indicator Light is performed in accordance with the regulations set forth in CARB mail-out 1968.1 and as demonstrated via the Federal Test Procedure (FTP). The following page provides several examples of when and how the Malfunction Indicator Light is illuminated based on the "customer drive cycle".

TEXT NO.	DRIVE CYCLE # 1			DRIVE CYCLE # 2			DRIVE CYCLE # 3			DRIVE CYCLE # 4			DRIVE CYCLE # 5			* DRIVE CYCLE # 43		
	FUNCTION CHECKED	FAULT CODE SET	MIL STATUS CHECK ENGINE	FUNCTION CHECKED	FAULT CODE SET	MIL STATUS CHECK ENGINE	FUNCTION CHECKED	FAULT CODE SET	MIL STATUS CHECK ENGINE	FUNCTION CHECKED	FAULT CODE SET	MIL STATUS CHECK ENGINE	FUNCTION CHECKED	FAULT CODE SET	MIL STATUS CHECK ENGINE	FUNCTION CHECKED	FAULT CODE ERASED	MIL STATUS CHECK ENGINE
1.	YES	YES	OFF															
2.	YES	YES	OFF	YES	YES	ON												
3.	YES	YES	OFF	NO	NO	OFF	YES	YES	ON									
4.	YES	YES	OFF	YES	NO	OFF	YES	NO	OFF	YES	YES	OFF	YES	YES	ON			
5.	YES	YES	OFF	YES	YES	ON	YES	NO	ON	YES	NO	ON	YES	NO	OFF			
6.	YES	YES	OFF	YES	YES	ON	YES	NO	ON	YES	NO	ON	YES	NO	OFF	YES	FAULT CODE ERASED	OFF

1. A fault code is stored within the ECM upon the first occurrence of a fault in the system being checked.
2. The "Malfunction Indicator Light" will not be illuminated until the completion of the second consecutive "customer driving cycle" where the previously faulted system is again monitored and a fault is still present or a catalyst damaging fault has occurred.
3. If the second drive cycle was not complete and the specific function was not checked as shown in the example, the ECM counts the third drive cycle as the "next consecutive" drive cycle. The "Malfunction Indicator Light" is illuminated if the function is checked and the fault is still present.
4. If there is an intermittent fault present and does not cause a fault to be set through multiple drive cycles, two complete consecutive drive cycles with the fault present are required for the "Malfunction Indicator Light" to be illuminated.
5. Once the "Malfunction Indicator Light" is illuminated it will remain illuminated unless the specific function has been checked without fault through three complete consecutive drive cycles.
6. The fault code will also be cleared from memory automatically if the specific function is checked through 40 consecutive drive cycles without the fault being detected or with the use of either the DISplus, GT1 or Scan tool.

NOTE: In order to clear a catalyst damaging fault (see Misfire Detection) from memory, the condition must be evaluated for 80 consecutive cycles without the fault reoccurring.

Workshop Hints

Before any service work is performed on any fuel system related component, always adhere to the following:

- Observe relevant safety legislation pertaining to your area.
- Ensure adequate ventilation.
- Use exhaust extraction system where applicable (alleviate fumes).
- DO NOT SMOKE while performing fuel system repairs.
- Always wear adequate protection clothing including eye protection
- Use caution when working around a HOT engine compartment
- BMW does not recommend any UNAUTHORIZED MODIFICATIONS to the fuel system. The fuel systems are designed to comply with strict Federal Safety and Emissions Regulations. In the concern of product liability, it is unauthorized to sell or perform modifications to customer vehicles, particularly in safety areas.



The "Malfunction Indicator Light" can be diagnosed with an aftermarket Scan Tool that allows Technicians without BMW Special Tools or Equipment to Diagnose an emission system failure. With the use of a universal scan tool, connected to the **"OBD" DLC (located in the driver's side left lower instrument panel area)** an SAE standardized DTC can be obtained, along with the condition associated with the illumination of the "Malfunction Indicator Light". Using the DISplus or GT1, a fault code and the conditions associated with its setting can be obtained prior to the illumination of the "Malfunction Indicator Light".

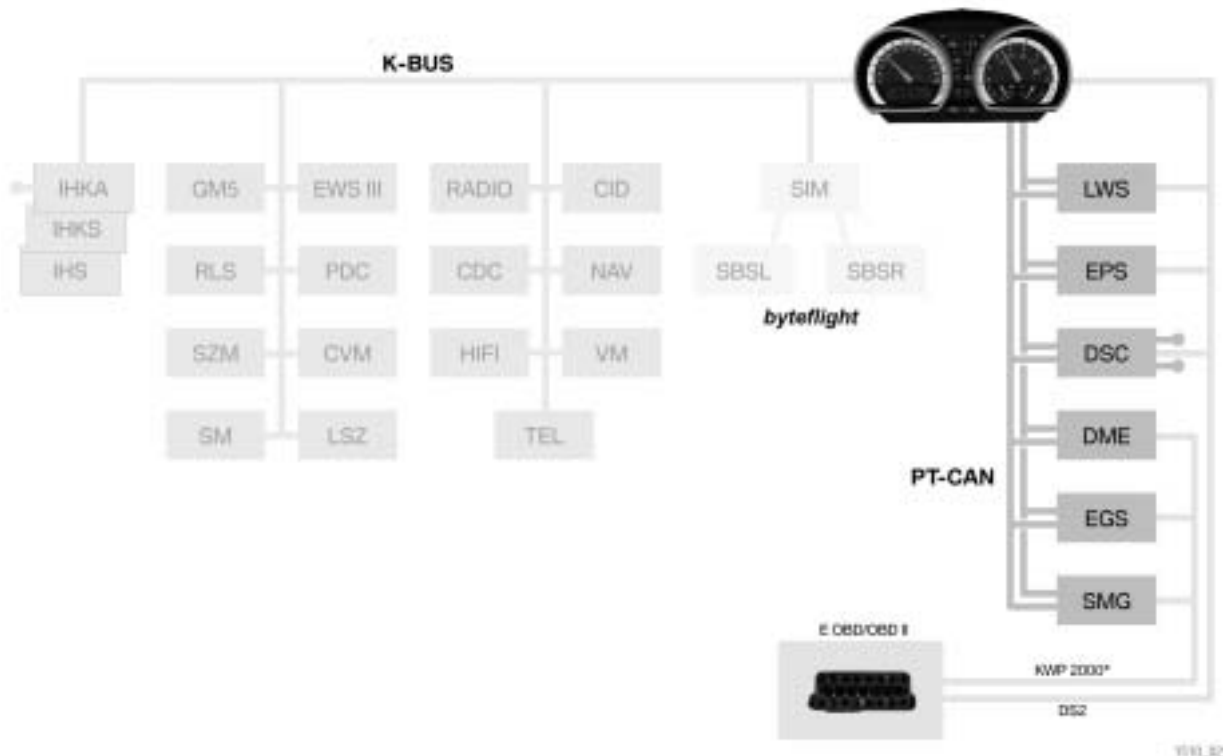

Misfire Detection

Refer to Service Information Bulletin **S.I. #12 02 97** for details about Misfire Fault Codes.

Testing the Oxygen Sensor should be performed using the DISplus Oscilloscope from the “Preset Measurement” List. The scope pattern should appear as below for a normal operating sensor.

If the signal remains high (rich condition) the following should be checked:

- Fuel Injectors
- Fuel Pressure
- Ignition System
- Input Sensors that influence air/fuel mixture
- Engine Mechanical

If the signal remains low (lean condition) the following should be checked:

- Air/Vacuum leak
- Fuel Pressure
- Input Sensor that influence air/fuel mixture
- Engine Mechanical

NOTE: A MIXTURE RELATED FAULT CODE SHOULD BE INVESTIGATED FIRST AND DOES NOT ALWAYS INDICATE A DEFECTIVE OXYGEN SENSOR!

Check Filler Cap (additional information from page 72)

After refueling and switching the ignition “ON”, the ECM detects a fuel level increase. When the ignition is switched “OFF”, the ECM activates the DM TL for a “brief test” to check the filler cap. If the filler cap was not properly installed; when the vehicle is started and driven at a speed >10 Km/h, the “Check Filler Cap” light will illuminate for 25 seconds (and then go out).

The second time the ignition is cycled “OFF”, the DM TL is activated to test the filler cap. If loose; when the vehicle is started and driven at a speed >10 Km/h, the “Check Filler Cap” light will be illuminated for 25 seconds (and then go out).

If the filler cap is properly secured, the “Malfunction Indicator Light” will *not* be illuminated and a fault code will not be stored in the ECM.

The third time the ignition is cycled “OFF”, the DM TL is activated to test the filler cap. If loose; a “Large Leak” fault code is stored in the ECM. The “Malfunction Indicator Light” will be illuminated the next time the engine is started.

Tools and Equipment

The DISplus/Gt1 as well as a reputable hand held multimeter can be used when testing inputs/components.

It is best to make the checks at the ECM connection, this method includes testing the wiring harness.

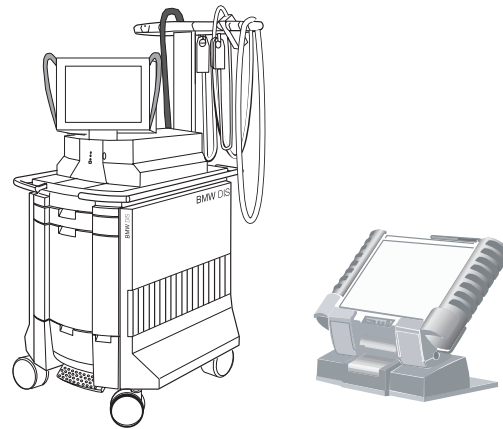

DISplus

GT-1

The correct Universal Adapter for the MS45 application should be used (#90 88 6 121 300). This will ensure the pin connectors and the harness will not be damaged.

When installing the Universal Adapter to the ECM (located below the windshield on the passenger side of the engine compartment), make sure the ignition is switched off.

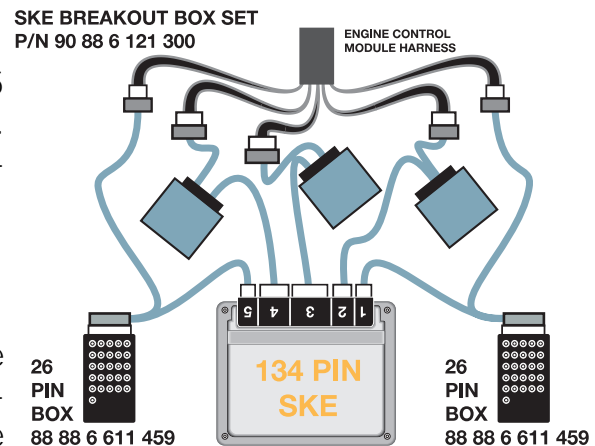

NOTE for MS45: Allow at least 3 minutes to elapse after the key was set to the "OFF" position before disconnecting the ECM/ TCM.

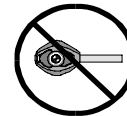

This will allow sufficient time to complete the DM TL test. Voltage may be present (up to 3 minutes) causing damage to the ECM/TCM if they are disconnected during this time period (arcing).

Performance Controls

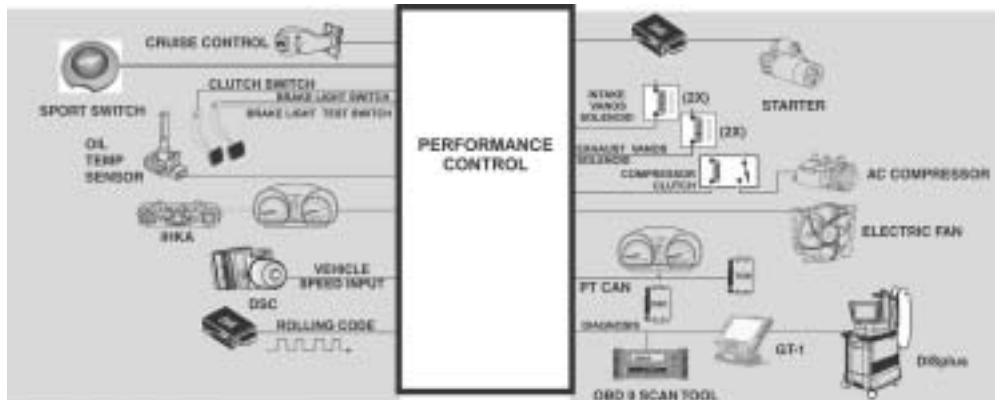

Dynamic Driving Control (if equipped)

The MS45 ECM contains two different throttle progression functions (Sport and Normal). The Dynamic Driving Control function is selected by pressing the “Sport” button located in the center console (1).

The switch provides a ground signal (input) to the ECM when pressed. The MS45 activates the sport characteristics for the Electronic throttle control (EDK). This provides an increase in throttle opening and response time over the non-sport position.



kt-10288

When this function is activated, the function indicator light in the Sport button is illuminated by the Electric Power Steering (EPS) Control Module. When the ignition is cycled, this function resets back to the non-sport function (it must be re-selected by the driver).

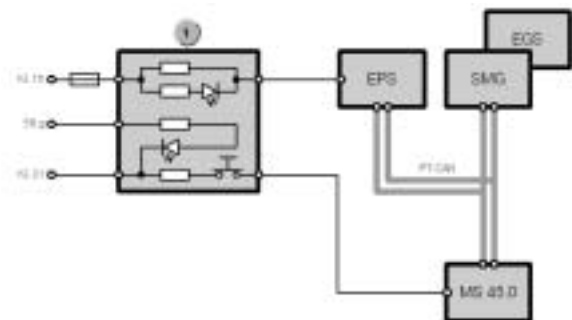

kt-10057

- Electronic Power Steering (EPS)
- Instrument cluster (Kombi)

If equipped:

- Automatic transmission (EGS)
- SMG 6-speed sequential manual gearbox

Note: Refer to the respective sections for the function influence on these systems.

Cruise Control

Cruise control functions are activated directly from the stalk (lever) to the ECM. The individual positions (requests) are digitally encoded and are input to the ECM over a serial data wire. The cruise control operational requirements are BMW “typical”. *The E85 does not have a “system on” indicator light.*

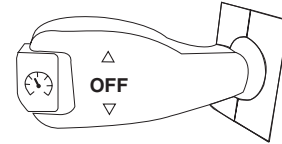

Cruise Control is integrated into the ECM because of the EDK operation.

45-02-06

- The ECM controls vehicle speed by activation of the Electronic Throttle Valve (EDK).
- The clutch switch disengages cruise control to prevent over-rev during gear changes.
- The brake light switch and the brake light test switch are input to the ECM to disengage cruise control as well as fault recognition during engine operation of the EDK.

Road speed is input to the ECM for cruise control as well as DSC regulation. The road speed signal for cruise control is supplied by the DSC Control module.

Electric Fan

The electric cooling fan is controlled by the ECM for engine cooling system and air conditioning system requirements. The ECM uses a remote power output final stage (mounted on the fan housing). The electric fan is controlled by a pulse width modulated signal from the ECM.

The fan (and speed) is activated by the ECM based on:

- Coolant outlet temperature
- Catalyst temperature (calculated by the ECM)
- Vehicle speed
- Battery voltage
- Air Conditioning refrigerant pressure (calculated by IHKA and sent via the PT CAN bus to the ECM)

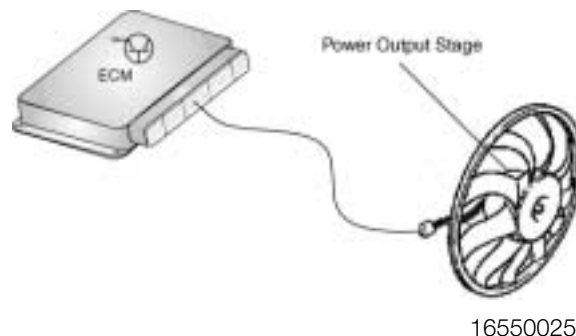

ECM Integrated Temperature Sensor

The E Box fan is controlled by the MS45 ECM. The control module contains an integral NTC temperature sensor for the purpose of monitoring the E box temperature and activating the fan.

When the internal temperature exceeds 65° C, the ECM provides a switched ground for the E Box fan to cool the E box control modules.

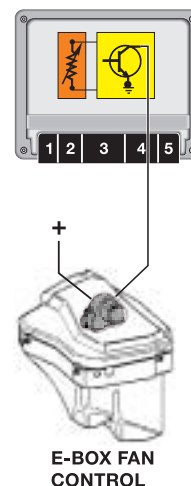

Alternator Interface

The alternator communicates data with the ECM via the BSD line (bit-serial data interface - single wire). This is necessary to allow the ECM to adapt its calculations and specific control data to the alternator output. In addition, the ECM controls the following functions:

- Activation/deactivation of the alternator.
- Informing the voltage regulator of the nominal voltage value to be set.
- Controlling the alternator's load response.
- Diagnosing the BSD line.
- Storing alternator fault codes.
- Activating the charging indicator light in the instrument cluster.

The charging indicator light switch operation has not changed from present vehicles.

EWS III (3.3)

The electronic driveaway protection system (EWS III) remains unchanged from the current E46 BMW models.

PT CAN Bus Communication

The ECM provides signals to other “driveline” related modules for torque control, shift quality, diagnosis, safety enhancements, etc. This is covered in the appropriate sections.

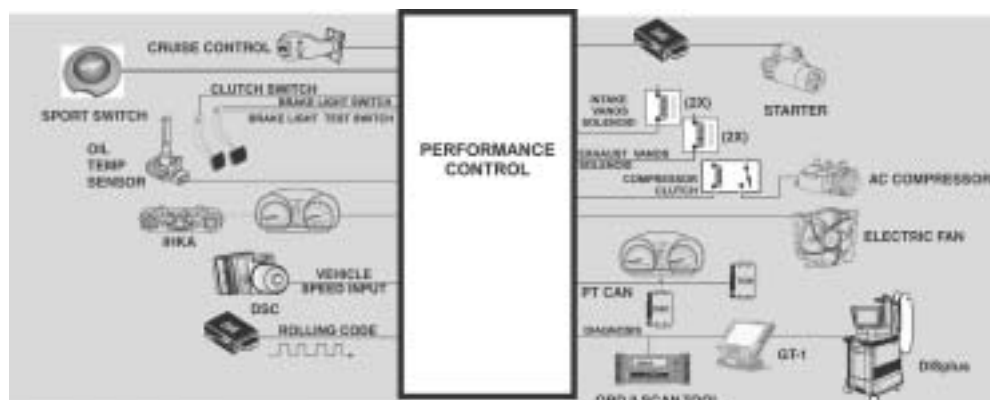

45-02-05

Dual VANOS Control

Performance, torque, idle characteristics and exhaust emissions reduction are improved by Variable Camshaft Timing (VANOS). The VANOS unit is mounted directly on the front of the cylinder head and adjusts the *Intake and Exhaust* camshaft timing from retarded to advanced. The ECM controls the operation of the VANOS solenoid which regulates the oil pressure required to move the control piston. Engine RPM, load and temperature are used to determine VANOS activation.

VANOS mechanical operation is dependent on engine oil pressure applied to position the control pistons. When oil pressure is applied to the control pistons (regulated by the solenoids), the pistons move causing the splined adjustment shafts to move. The straight splines slide within the camshaft sleeves. The helical splines rotate the camshaft drive sprockets changing the position in relation to the camshaft position which advances/retards the intake/exhaust camshaft timing.

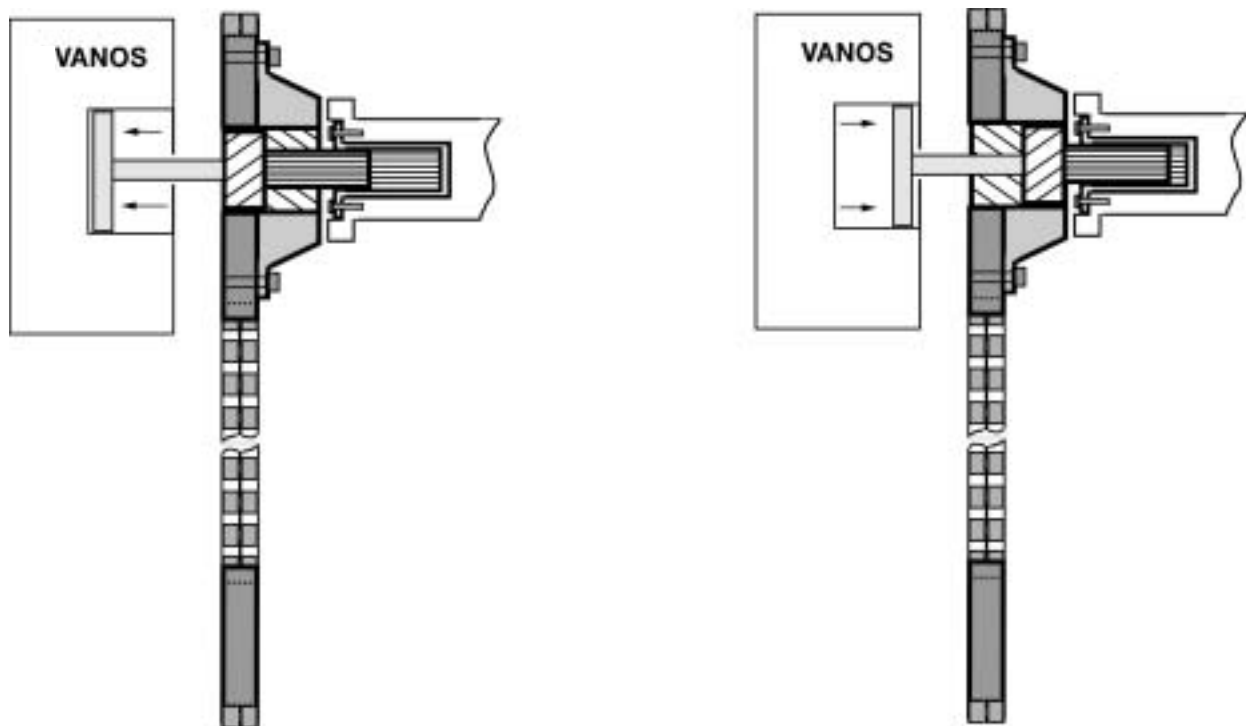

135500066

The operation of the VANOS solenoid is monitored in accordance with the OBD II requirements for emission control. The ECM monitors the final stage output control and the signal from the Camshaft Position Sensors for VANOS operation.

Dual VANOS consists of the following parts:

- Intake and exhaust camshafts with helical gear insert
- Sprockets with adjustable gears
- VANOS actuators for each camshaft
- 2 three-way solenoid switching valves
- 2 impulse wheels for detecting camshaft position
- 2 camshaft position sensors (Hall effect)

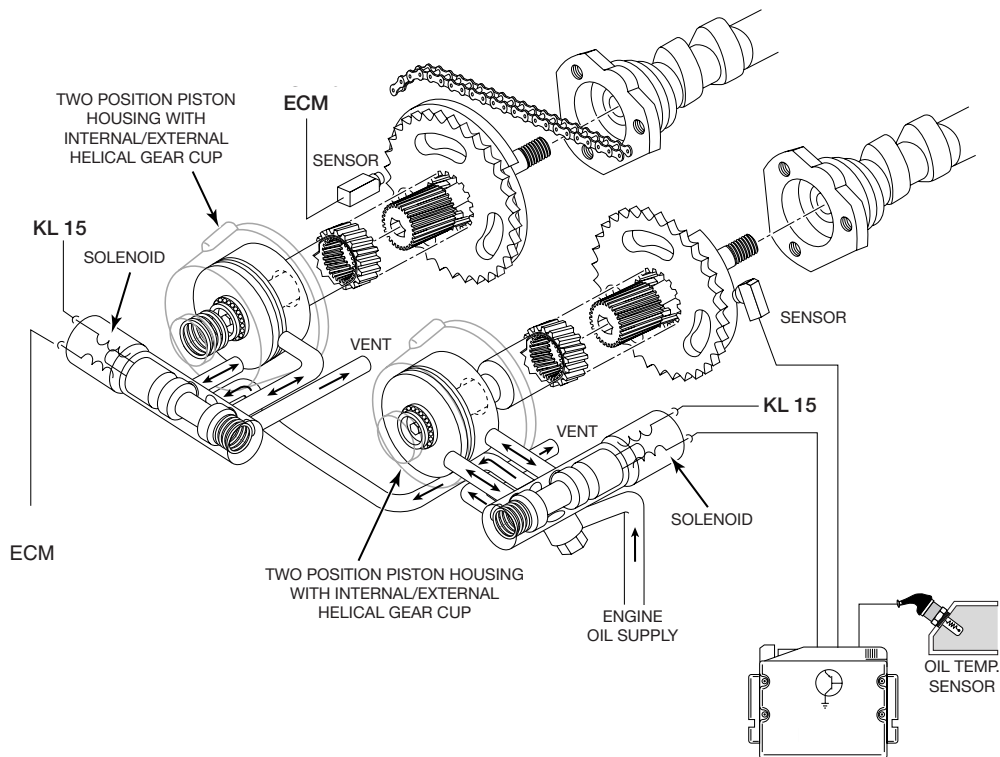

When the engine is started, the camshafts are in the “failsafe” position (deactivated). The intake camshaft is in the RETARDED position - held by oil pressure from the sprung open solenoid. The exhaust camshaft is in the ADVANCED position - held by a preload spring in the actuator and oil pressure from the sprung open solenoid.

After 50 RPM (2-5 seconds) from engine start, the ECM is monitoring the exact camshaft position. The ECM positions the camshafts based on engine RPM and the throttle position signal. From that point the camshaft timing will be varied based on intake air and coolant temperatures.

The dual VANOS system is “fully variable”. When the ECM detects the camshafts are in the optimum positions, the solenoids are modulated (approximately 100-220 Hz) maintaining oil pressure on both sides of the actuators to hold the camshaft timing.

CAUTION: The VANOS **MUST** be removed and installed exactly as described in the Repair Instructions!

NOTE: If the VANOS camshaft system goes to the failsafe mode (deactivated) there will be a noticeable loss of power.

DEACTIVATED

EXHAUST: Advanced - piston moved in

INTAKE: Retard - piston moved out

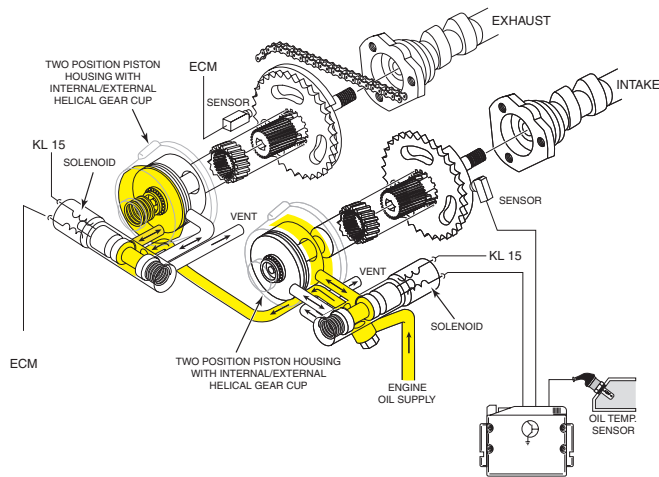

ACTIVATED

EXHAUST: Advanced - piston moved out

INTAKE: Retard - piston moved in

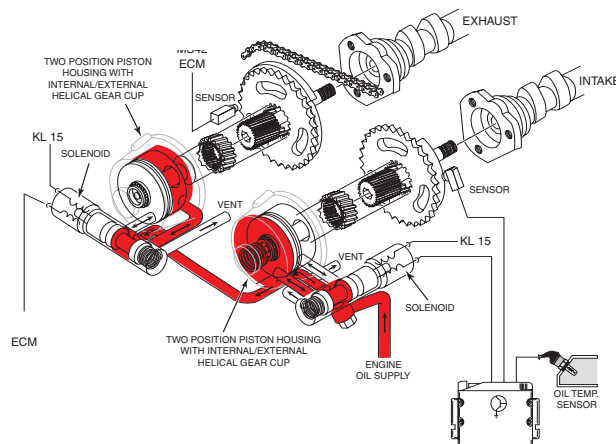

ECM Programming - FLASH Control Modules

The MS45 ECM is a programmable “FLASH” Control Module. The ECM contains a soldered in *FLASH EPROM* which can be programmed/updated up to 13 times. The EPROM has basic information always present in it referred to as “resident data”. This resident data gives the EPROM its identification and contains instructions for the programming of the operational maps. When you program, you are inputting operational maps to the ECM such as injection timing and ignition timing, etc.

Always refer to the latest programming IDC Bulletin for a complete list of FLASH programmable control modules and the latest program highlights. ***An unprogrammed control module will not allow the engine to start.*** DME (ECM) FLASH programming is performed with the DISplus/GT1 using the latest software.

Using the “automatic” determination process (preferred method), the GT1 compares the part numbers stored in the FLASH EPROM of the currently installed ECM with a list of possible replacement part numbers stored in the DISplus or GT1 memory. The comparison is done to:

- Display the part number for the replacement programmable control module for that vehicle.
- Determine if the GT1 can “ recommend” a replacement part number(s) from the list of part numbers stored in memory.
- Identify a proper replacement program or control module

Tools and Equipment

The DISplus/Gt1 as well as a reputable hand held multimeter can be used when testing inputs/components.

It is best to make the checks at the ECM connection, this method includes testing the wiring harness.

The correct Universal Adapter for the MS45 application should be used (#90 88 6 121 300). This will ensure the pin connectors and the harness will not be damaged.

When installing the Universal Adapter to the ECM (located below the windshield on the passenger side of the engine compartment), make sure the ignition is switched off.

NOTE for MS45: Allow at least 3 minutes to elapse after the key was set to the "OFF" position before disconnecting the ECM/ TCM.

This will allow sufficient time to complete the DM TL test. Voltage may be present (up to 3 minutes) causing damage to the ECM/TCM if they are disconnected during this time period (arcing).

VANOS

The electrical/hydraulic function can be checked "statically" by using the adapter tools and shop supplied **regulated** compressed air.

Special Tool # 90 88 6 113 450 adapts regulated compressed air to substitute for engine oil pressure required to move the VANOS piston. Special Tool # 90 88 6 126 410 allows battery voltage and ground to activate the solenoid.

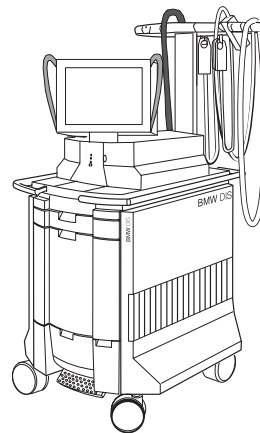

DISplus



GT-1

16550019

SKE BREAKOUT BOX SET
P/N 90 88 6 121 300

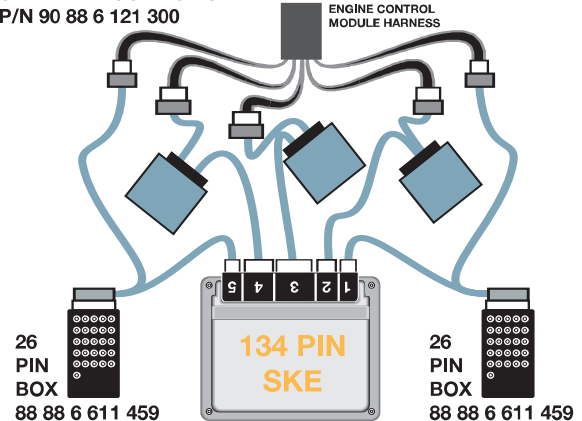

16550020

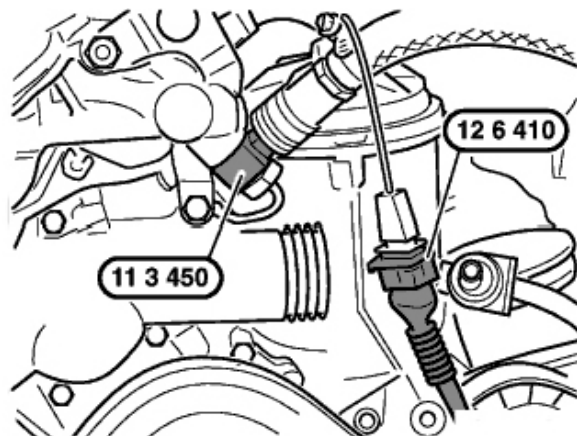
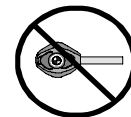

135500076

Review Questions

1. Describe the Power Supply for the MS45 Fuel Injectors and Ignition Coils:

2. Name the Components of the MS45 Fuel Supply System that are “integral” in the fuel tank:

3. List the inputs required for Fuel Injector operation:

4. Describe the Emission Optimized Function: _____

5. Name two types of Emissions the ECM controls: _____

6. What two sensors are used to monitor MS45 accelerator movement?

7. Why are there two inputs from the Accelerator Module? _____

8. Where is the DM TL located on an E85? _____

9. Why does the MS45 have multiple ignition pulses? _____

10. How is the ignition system monitored? _____
